



Top Load Washer

PRODUCT MODEL NUMBERS

WTW8200Y, WTW8240Y, WTW8400Y,
WTW8440Y, WTW8600Y, WTW8800Y

Installation spacing for recessed area or closet installation

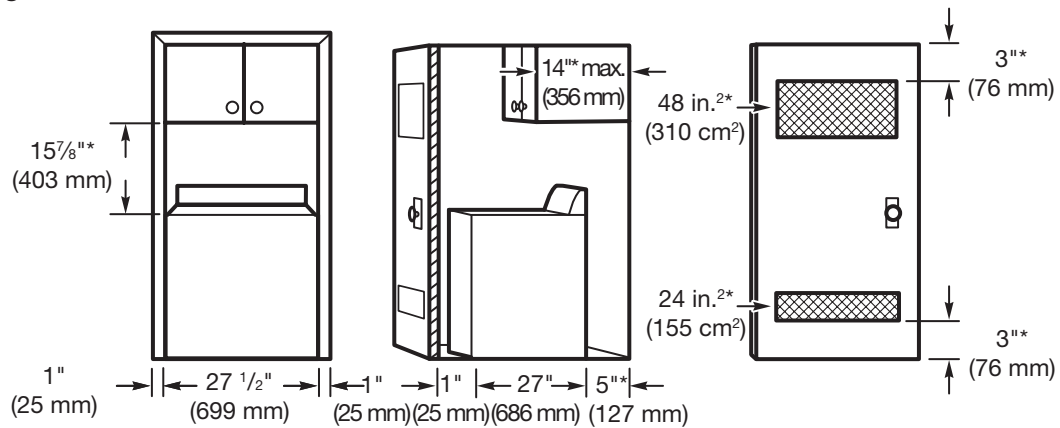

* Required spacing

Front view

Side view

Closet door
with vents

The dimensions shown show recommended spacing allowed, with tested spacing of 0" (0 mm) clearance on sides.

- Additional clearances might be required for wall, door, floor moldings.
- Additional spacing should be considered for ease of installation and servicing.
- Additional spacing on all sides of the washer is recommended to reduce noise transfer.
- For closet installation, with a door, minimum ventilation openings in the top and bottom of the door are required. Louvered doors with equivalent ventilation openings are acceptable.
- Companion appliance spacing should also be considered.

ELECTRICAL REQUIREMENTS

A 120 volt, 60 Hz., AC only, 15- or 20-amp, fused electrical supply is required. A time-delay fuse or circuit breaker is recommended. It is recommended that a separate circuit serving only this appliance be provided.

DRAIN SYSTEM

The washer can be installed using the standpipe drain system (floor or wall), the laundry tub drain system, or the floor drain system. Select the drain hose installation method you need.

Floor standpipe drain system

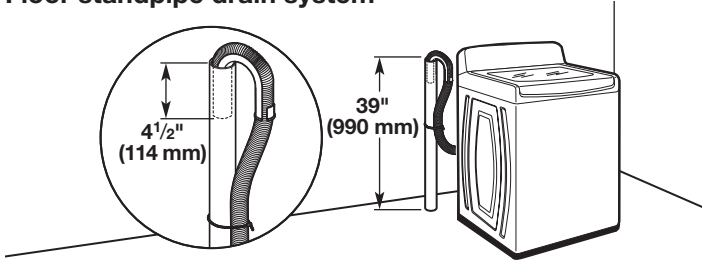

Minimum diameter for a standpipe drain: 2" (51 mm). Minimum carry-away capacity: 17 gal. (64 L) per minute. Top of standpipe must be at least 39" (990 mm) high; install no higher than 96" (2.4 m) from bottom of washer. If you must install higher than 96" (2.4 m), you will need a sump pump system.

Wall standpipe drain system

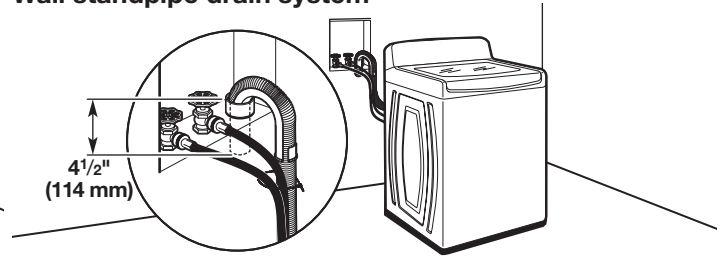

See requirements for floor standpipe drain system.

Floor drain system

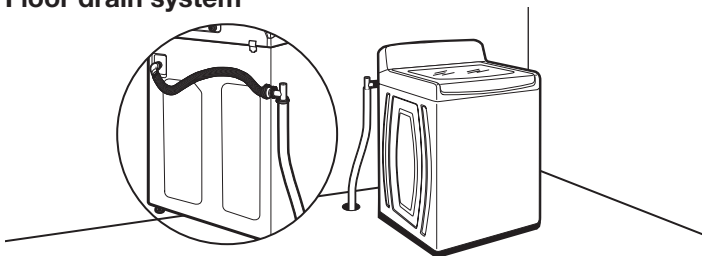

Floor drain system requires a Siphon Break Kit (Part Number 285834), 2 Connector Kits (Part Number 285835), and an Extension Drain Hose (Part Number 285863) that may be purchased separately. To order, please see toll-free phone numbers in your "Use and Care Guide." Minimum siphon break: 28" (710 mm) from bottom of washer. (Additional hoses may be needed.)

Laundry tub drain system

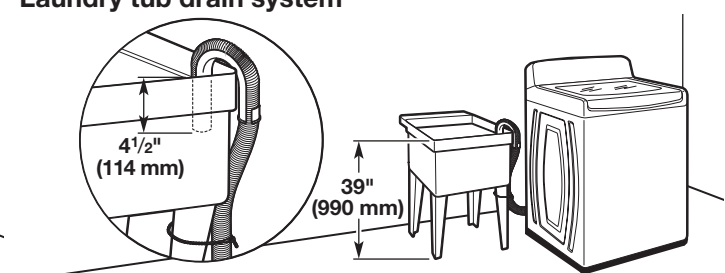

Minimum capacity: 20 gal. (76 L). Top of laundry tub must be at least 39" (990 mm) above floor; install no higher than 96" (2.4 m) from bottom of washer.

IMPORTANT: To avoid siphoning, no more than 4 1/2" (114 mm) of drain hose should be inside standpipe or below the top of wash tub. Secure drain hose with cable tie.