

Specifications

BUILT-IN MODELS

Interior Capacity	R cu ft (L)	F cu ft (L)
<b>ALL REFRIGERATOR / ALL FREEZER MODELS</b>		
BI-36R	23.5 (665)	
BI-36RG	23.4 (663)	
BI-36F		22.7 (643)
<b>OVER-AND-UNDER MODELS</b>		
BI-30U	13.2 (374)	4.2 (119)
BI-30UG	13.1 (371)	4.2 (119)
BI-36U	16.4 (464)	5.3 (150)
BI-36UG	16.3 (462)	5.3 (150)
BI-36UFD	15.7 (445)	5.3 (150)
<b>SIDE-BY-SIDE MODELS</b>		
BI-36S	12.4 (351)	8.2 (232)
BI-42S	16.3 (462)	8.0 (227)
BI-42SID	15.8 (447)	7.9 (224)
BI-42SD	16.0 (453)	7.9 (224)
BI-48S	19.1 (541)	9.8 (278)
BI-48SID	18.6 (527)	9.6 (272)
BI-48SD	18.8 (532)	9.6 (272)

Shipping Weight	lbs (kg)
<b>ALL REFRIGERATOR / ALL FREEZER MODELS</b>	
BI-36R	420 (191)
BI-36RG	430 (195)
BI-36F	406 (184)
<b>OVER-AND-UNDER MODELS</b>	
BI-30U	462 (210)
BI-30UG	476 (216)
BI-36U	515 (234)
BI-36UG	529 (240)
BI-36UFD	529 (240)
<b>SIDE-BY-SIDE MODELS</b>	
BI-36S	538 (244)
BI-42S	582 (264)
BI-42SID	608 (276)
BI-42SD	608 (276)
BI-48S	630 (286)
BI-48SID	656 (298)
BI-48SD	656 (298)

Overall Dimensions

ALL REFRIGERATOR / ALL FREEZER MODELS

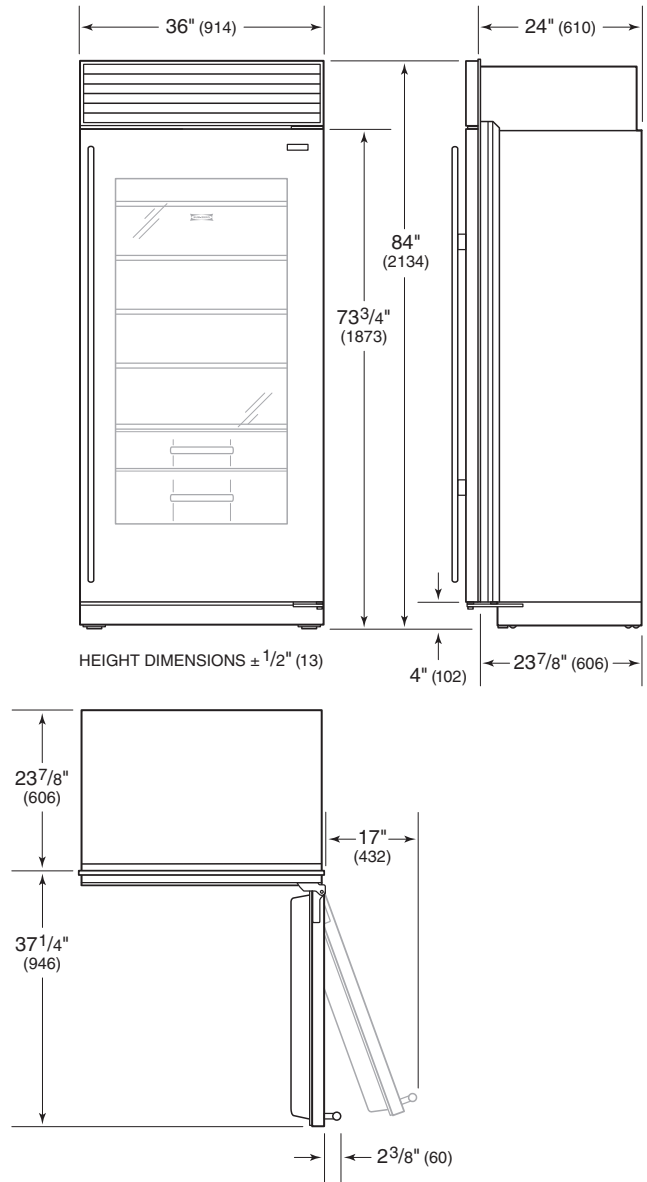

MODELS BI-36R, BI-36RG AND BI-36F

Shipping weights and overall dimensions are based on stainless steel models. For flush inset applications, add 1/2" (13) to door clearance dimensions.

Overall Dimensions

OVER-AND-UNDER MODELS

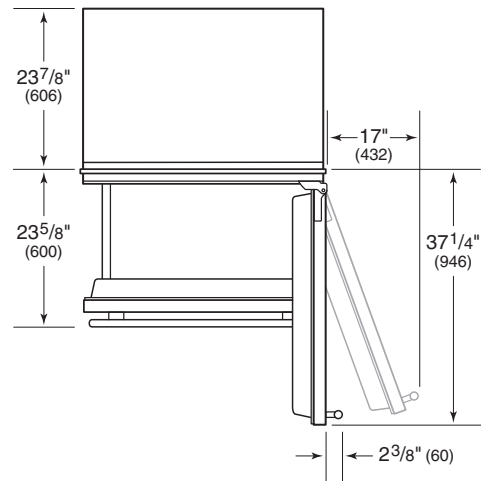
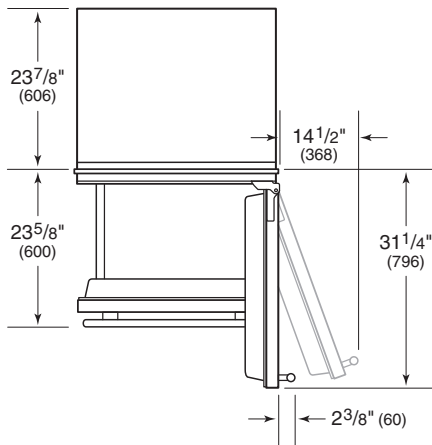
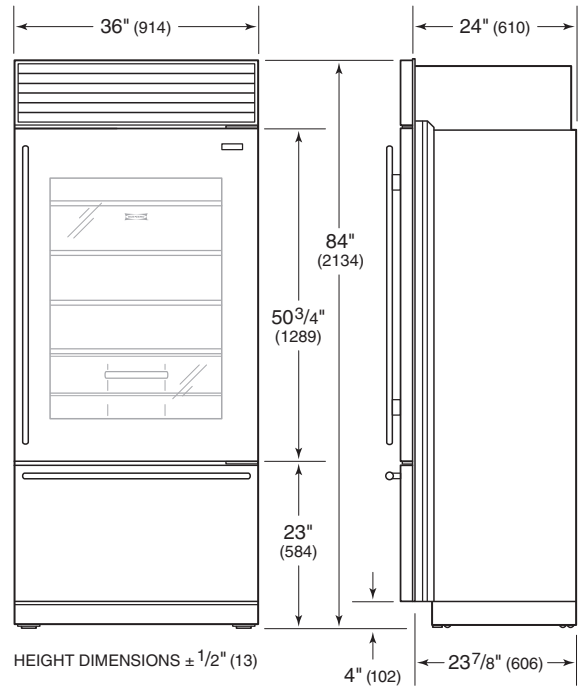
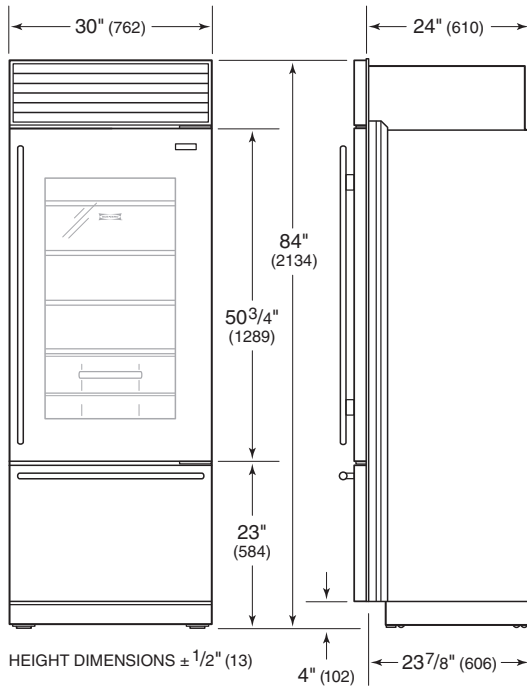

MODELS BI-30U AND BI-30UG

MODELS BI-36U AND BI-36UG

Overall Dimensions

OVER-AND-UNDER MODELS

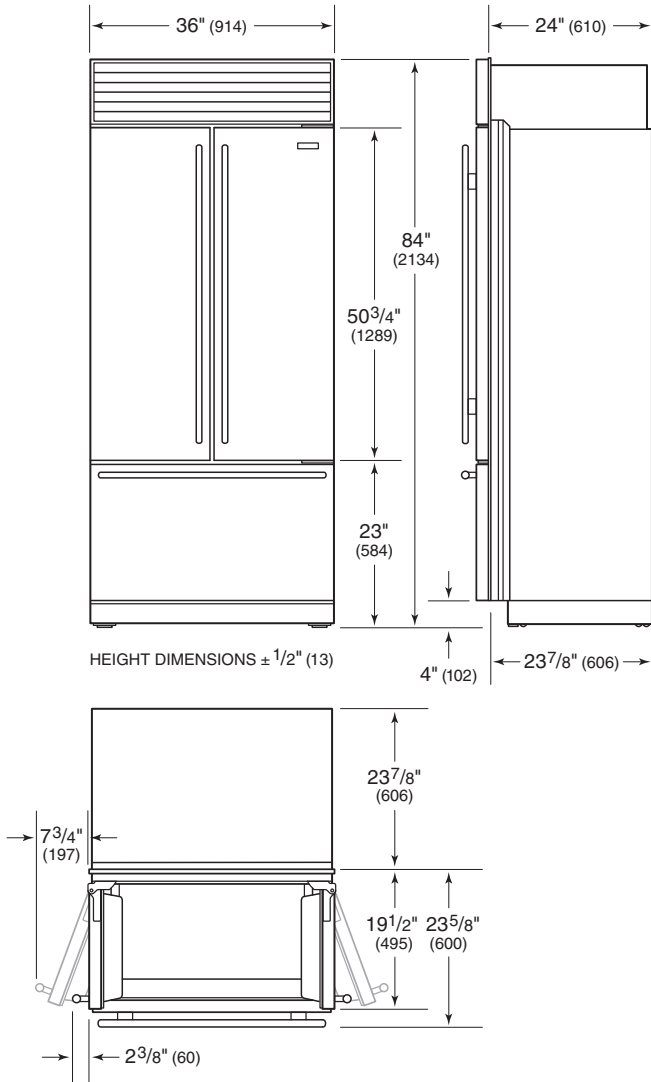

MODEL BI-36UFD

SIDE-BY-SIDE MODELS

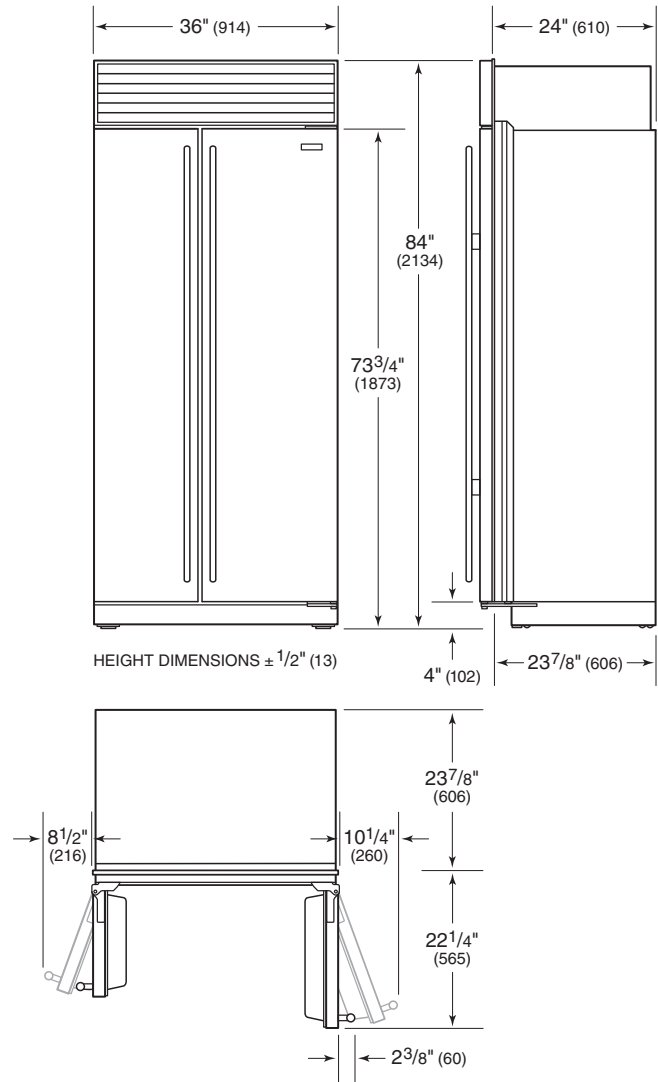

MODEL BI-36S

Overall dimensions are based on stainless steel models.  
 For flush inset applications, add 1/2" (13) to door clearance dimensions.

Overall Dimensions

SIDE-BY-SIDE MODELS

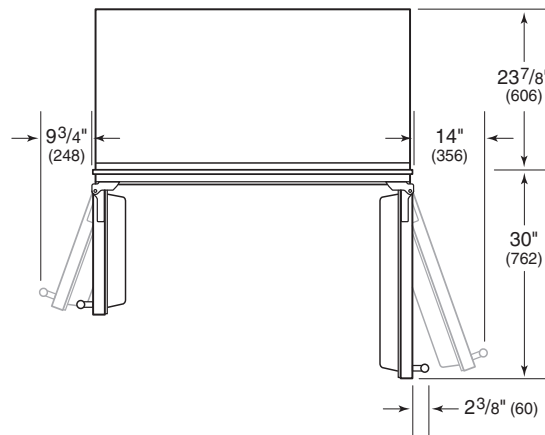
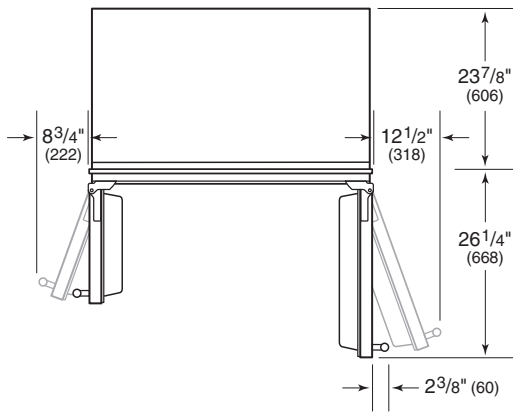
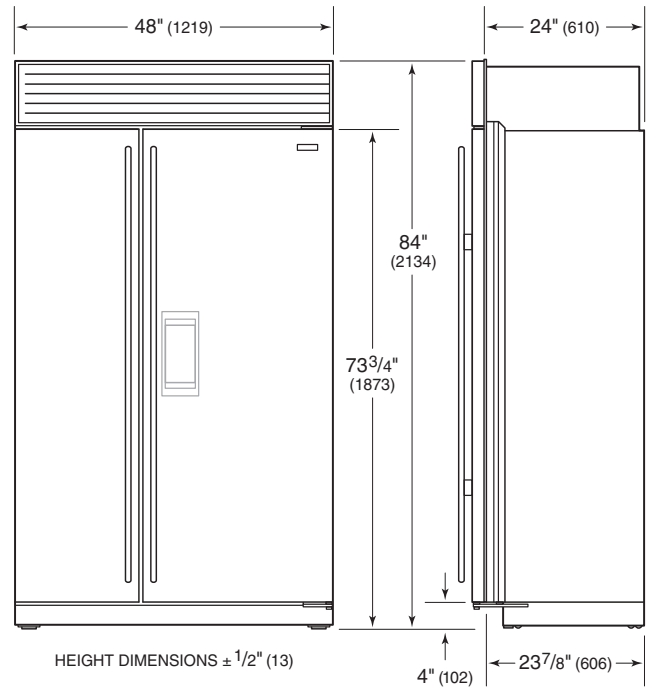
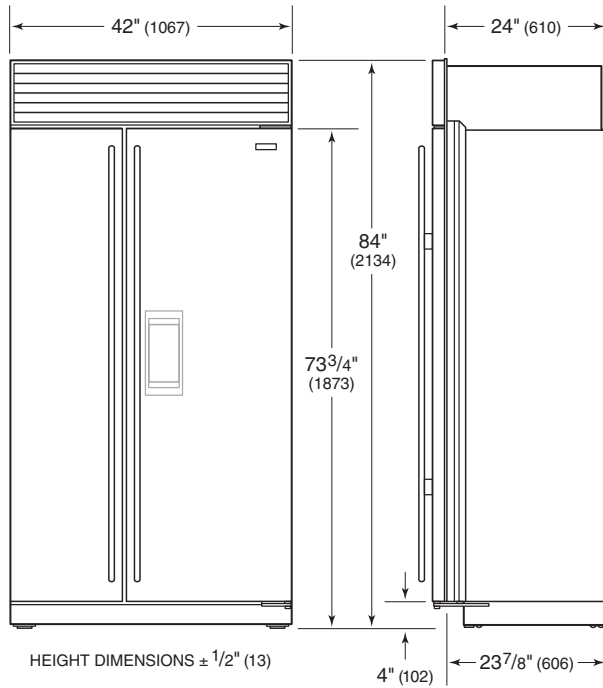

MODELS BI-42S, BI-42SID AND BI-42SD

MODELS BI-48S, BI-48SID AND BI-48SD

## Opening Dimensions

### STANDARD INSTALLATION

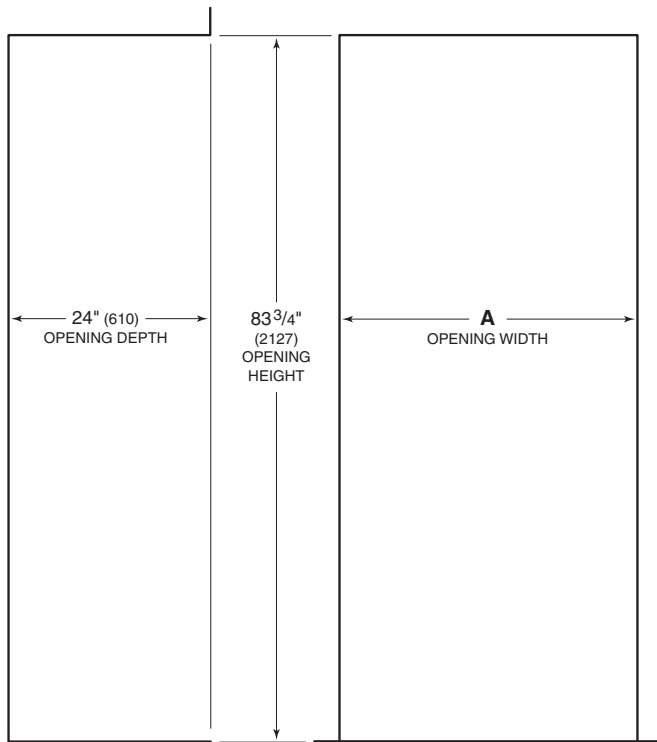
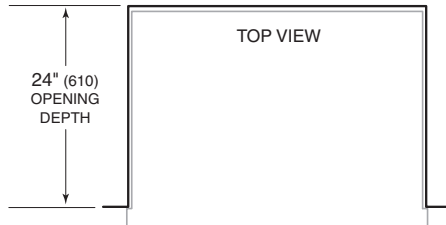

SIDE VIEW

FRONT VIEW

Opening Width	A
BI-36R, BI-36RG and BI-36F	35 1/2" (902)
BI-30U and BI-30UG	29 1/2" (746)
BI-36U, BI-36UG and BI-36UFD	35 1/2" (902)
BI-36S	35 1/2" (902)
BI-42S, BI-42SID and BI-42SD	41 1/2" (1054)
BI-48S, BI-48SID and BI-48SD	47 1/2" (1206)

**IMPORTANT NOTE:** If two units are installed side by side, refer to page 10 for dual standard installations.

Stainless steel models are ready to install out of the box.

## Opening Dimensions

### FLUSH INSET INSTALLATION

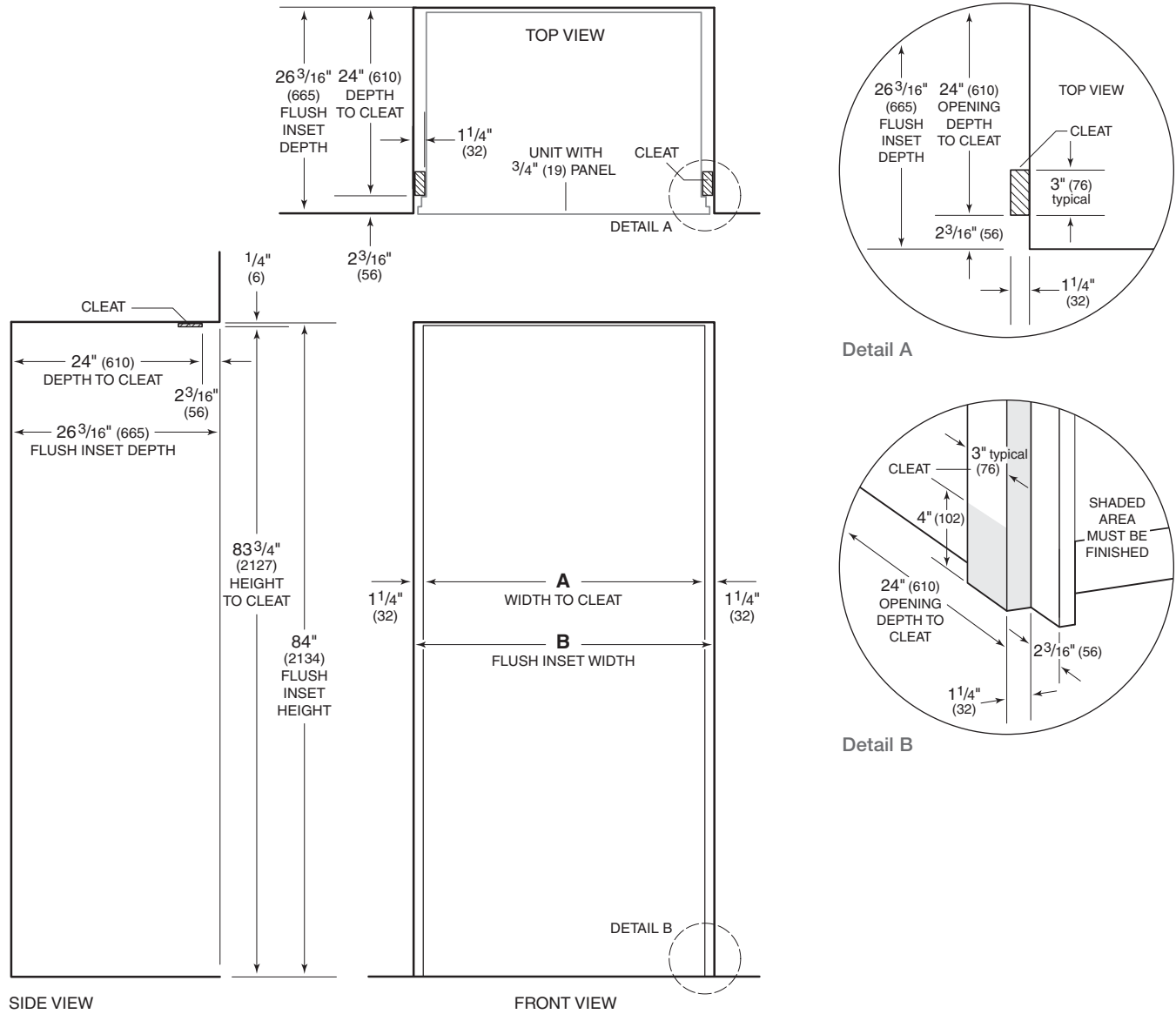

Flush Inset Opening Widths	A	B
BI-36R, BI-36RG and BI-36F	35 1/2" (902)	38" (965)
BI-30U and BI-30UG	29 1/2" (746)	32" (813)
BI-36U, BI-36UG and BI-36UFD	35 1/2" (902)	38" (965)
BI-36S	35 1/2" (902)	38" (965)
BI-42S, BI-42SID and BI-42SD	41 1/2" (1054)	44" (1118)
BI-48S, BI-48SID and BI-48SD	47 1/2" (1206)	50" (1270)

**IMPORTANT NOTE:** Dimensions assume a 3/4" (19) panel thickness.

**IMPORTANT NOTE:** If two units are installed side by side, refer to page 11 for dual flush inset installations.

## Dual Installation Opening Dimensions

### STANDARD INSTALLATION

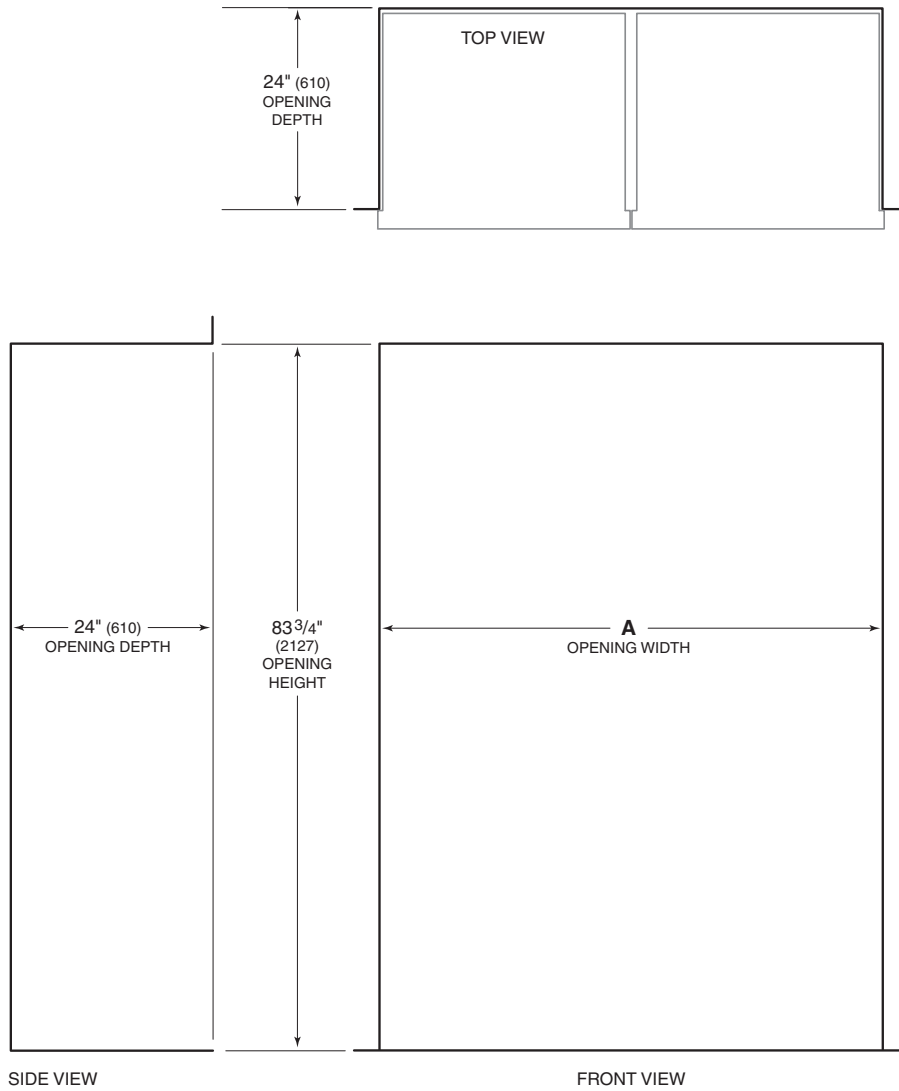

Opening Widths	A
Two 30" (762) Models	59 3/4" (1518)
30" (762) and 36" (914) Models	65 3/4" (1670)
Two 36" (914) Models	71 3/4" (1822)

**IMPORTANT NOTE:** A dual installation kit will be required for this installation.

Stainless steel models are ready to install out of the box.

## Dual Installation Opening Dimensions

### FLUSH INSET INSTALLATION

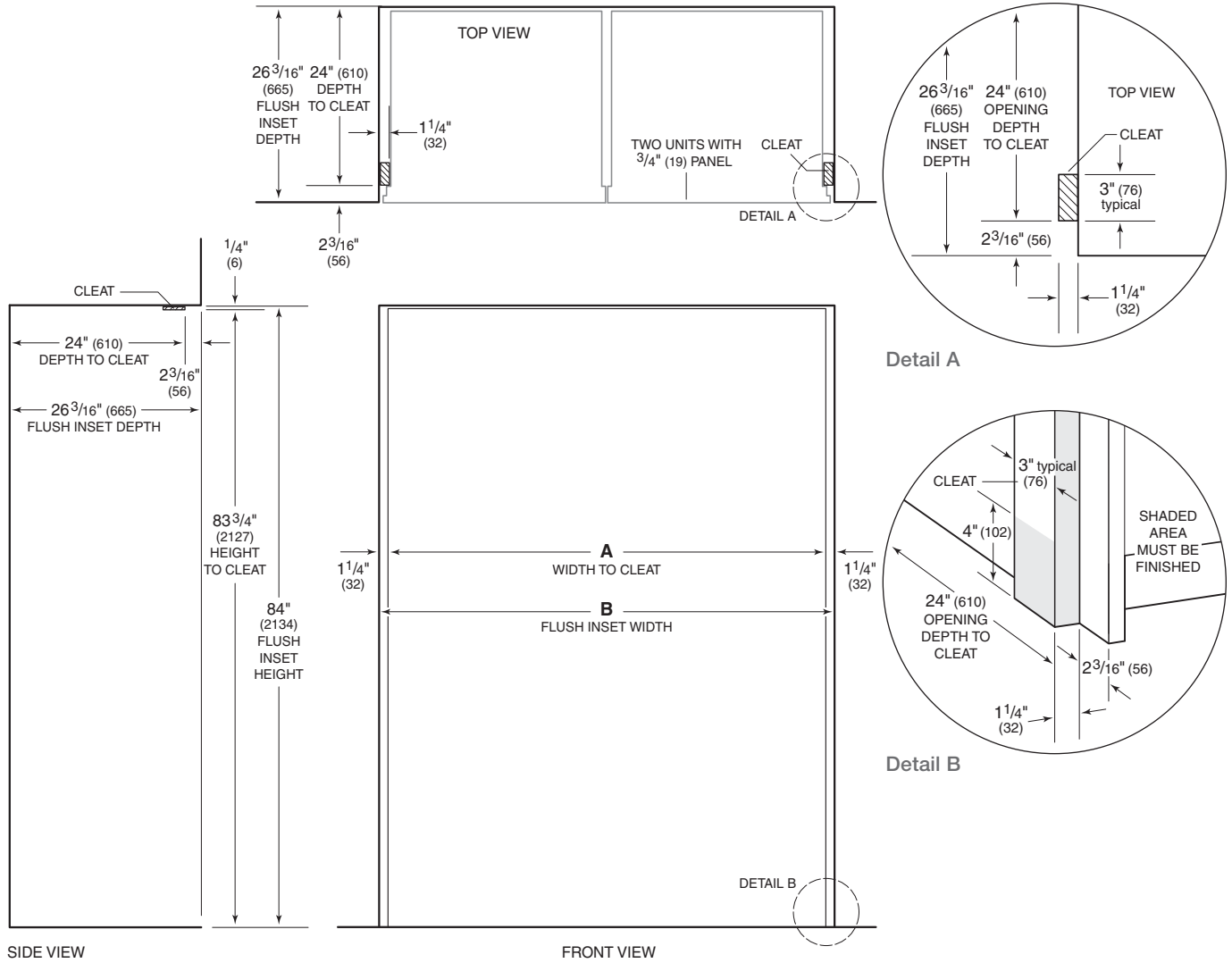

Opening Widths	A	B
Two 30" (762) Models	59 $\frac{3}{4}$ " (1518)	62 $\frac{1}{4}$ " (1581)
30" (762) and 36" (914) Models	65 $\frac{3}{4}$ " (1670)	68 $\frac{1}{4}$ " (1734)
Two 36" (914) Models	71 $\frac{3}{4}$ " (1822)	74 $\frac{1}{4}$ " (1886)

**IMPORTANT NOTE:** Dimensions assume a  $\frac{3}{4}$ " (19) panel thickness. A dual installation kit will be required for this installation.



### Site Preparation

Make sure that the finished rough opening where the built-in unit is being installed is properly prepared. Refer to the overall dimensions and installation specifications for your specific model. These specifications are identical for the framed, overlay and stainless steel applications. Installation specifications are different for the flush inset application, whether you are using custom panels or Sub-Zero accessory flush inset panels.

Make sure the opening dimensions, door and drawer clearances, electrical service and plumbing are correct for the model you are about to install. The floor under the unit must be level with the surrounding finished floor.

To operate properly, the door must open a minimum of 90°. Use a minimum 3" (76) filler in corner installations to assure a 90° door opening. Allow enough clearance in front of the unit for full door swing.

If you are installing two built-in units side by side in the framed, overlay, flush inset or stainless steel application, a separating filler strip is recommended. Add the filler strip width to the finished rough opening dimension.

For installation of two built-in units side by side without a filler strip, a dual installation kit will be necessary.

### Electrical Requirements

For all built-in models, the electrical supply should be located within the shaded area shown in the illustration. Follow the National Electrical Code and local codes and ordinances when installing the receptacle. A separate circuit, servicing only this appliance is required. A ground fault circuit interrupter (GFCI) is not recommended and may cause interruption of operation.

Electrical Requirements	
Power Supply	115 V AC, 60 Hz
Circuit Breaker	15 amp
Receptacle	3-prong grounding-type

**⚠ CAUTION**  
 The outlet must be checked by a qualified electrician to be sure that it is wired with the correct polarity. Verify that the outlet is properly grounded.

**⚠ WARNING**  
 Do not use an extension cord or two-prong adapter. Do not remove the power supply cord ground prong.

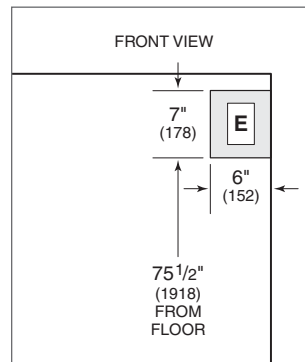

Location of electrical supply.

### Plumbing Requirements

All built-in models with an automatic ice maker feature a water filtration system that supplies filtered water to the ice maker and water dispenser (dispenser models). The water supply line should be located within the shaded area shown in the illustrations.

The water supply line should be connected to the house supply with an easily accessible shut-off valve between the supply and the unit. Do not use self-piercing valves. A saddle valve kit is available through your authorized Sub-Zero dealer. The water line must not interfere with installation of the anti-tip brackets.

A reverse osmosis system can be used provided there is constant water pressure of 35 psi (2.4 bar) to 120 psi (8.3 bar) supplied to the unit at all times. In this application, the water filtration system must be bypassed. Refer to water filter bypass mode on page 21. A copper line is not recommended for this application.

**IMPORTANT NOTE:** All installations must meet local plumbing code requirements.

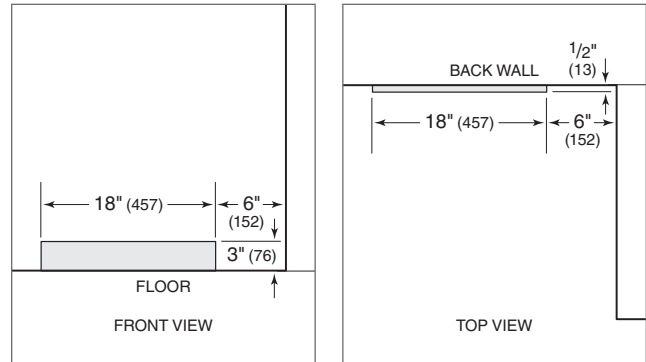

Location of water supply—rear.

Location of water supply—bottom.

Plumbing Requirements	
Water Supply Line	1/4" OD copper, braided stainless steel or PEX tubing
Water Pressure	35–120 psi (2.4–8.3 bar)
Excess Water Line for Connection	36" (914)

### Framed Panels

If your customer has chosen a framed design application, make sure that the panels you are about to install match dimensions listed in the framed panel specifications on pages 24–25. Additional panel design information can be found in the Sub-Zero design guide and on our website, [subzero.com](http://subzero.com).

If the thickness of the custom panel is less than a 1/4" (6), back it up with a sheet of shim material to build the total thickness to a 1/4" (6). If the panel is thicker than a 1/4" (6), rout an edge around the panel to achieve a proper fit. Refer to the illustrations.

**IMPORTANT NOTE:** On all built-in models, routing, recessing or optional extended handles may be required on raised panels for finger clearance under the handle.

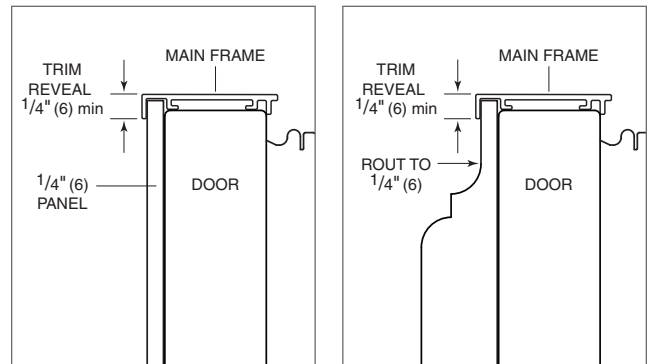

Panels 1/4" (6) thick or less.

Panels thicker than 1/4" (6).

Framed Panel Requirements	
<b>MAX WEIGHT PER PANEL</b>	
BI-36R, BI-36RG and BI-36F	75 lbs (34 kg)
All Other Framed Models	50 lbs (23 kg)
<b>MIN PANEL THICKNESS</b>	
All Framed Panels	1/4" (6)

## Framed Panels

To install framed panels, the door handle(s) must be removed. To install framed panels, first remove the door trim molding. For side-by-side models and the upper door for over-and-under models, insert a screwdriver tip into the top corner slot on the handle side and pop out the trim molding. Refer to the illustration below.

For the drawer on over-and-under models, insert a screwdriver tip into the slot on either side of the trim molding running along the top of the drawer, and pop out the trim molding. Refer to the illustration below.

With a screwdriver, remove the handles from the freezer and refrigerator doors. Slide the panel into the frame on the door. With the panel in position, replace the handles. Make sure the panel is inserted completely into the channel for proper fit and alignment.

To reinstall the trim molding, insert the top of the trim molding into the grooves at the top of the door and work downward, snapping the trim molding into the clips on the handle.

For the drawer on over-and-under models, start at one end and move towards the opposite end, snapping the trim molding into the clips on the handle.

## RAISED PANELS

You may have to rout, recess or use optional extended handles with some door panel designs to allow for finger clearance. This is particularly true if your unit has raised panels greater than  $\frac{1}{4}$ " (6) total thickness.

**IMPORTANT NOTE:** Do not exceed the maximum per panel weight for your specific model. Refer to the chart on the previous page.

Check the location of offset when you are using specific routing for the grip area only. Refer to the Sub-Zero design guide for a full-scale template of the standard full-length handle and panel. Use this grid template to lay out your panel design for finger clearance when standard full-length handles are used.

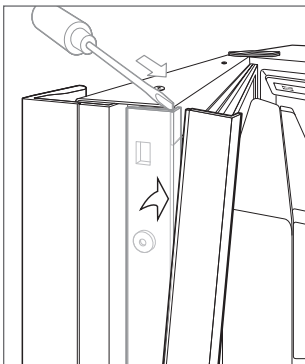

Door trim.

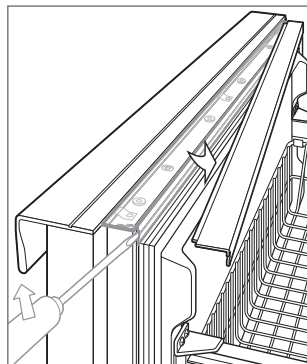

Over-and-under drawer trim.

Framed Panel Specifications

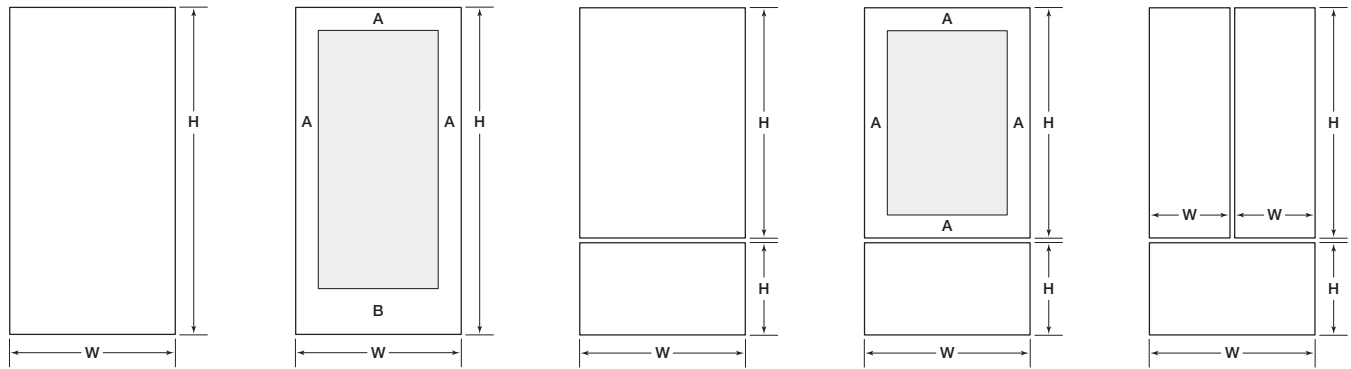

BI-36R / BI-36F

BI-36RG

BI-30U / BI-36U

BI-30UG / BI-36UG

BI-36UFD

Models BI-36R, BI-36RG and BI-36F			
<b>REFRIGERATOR/FREEZER</b>	<b>W</b>	<b>H</b>	
Door Panel	35 <sup>3</sup> / <sub>4</sub> " (908)	69 <sup>9</sup> / <sub>16</sub> " (1767)	
<b>BI-36RG</b>	<b>W</b>	<b>H</b>	
Window Cut-Out	25 <sup>1</sup> / <sub>2</sub> " (648)	54 <sup>1</sup> / <sub>16</sub> " (1373)	
Cut-Out Location	<b>A</b>	<b>B</b>	
	5 <sup>3</sup> / <sub>16</sub> " (132)	10 <sup>5</sup> / <sub>16</sub> " (262)	

Models BI-30U and BI-30UG			
<b>REFRIGERATOR</b>	<b>W</b>	<b>H</b>	
Door Panel	29 <sup>3</sup> / <sub>4</sub> " (756)	49 <sup>15</sup> / <sub>16</sub> " (1268)	
<b>FREEZER</b>	<b>W</b>	<b>H</b>	
Drawer Panel	29 <sup>3</sup> / <sub>4</sub> " (756)	18 <sup>11</sup> / <sub>16</sub> " (475)	
<b>BI-30UG</b>	<b>W</b>	<b>H</b>	
Window Cut-Out	19 <sup>1</sup> / <sub>2</sub> " (495)	39 <sup>11</sup> / <sub>16</sub> " (1008)	
Cut-Out Location	<b>A</b>		
	5 <sup>3</sup> / <sub>16</sub> " (132)		

Models BI-36U and BI-36UG			
<b>REFRIGERATOR</b>	<b>W</b>	<b>H</b>	
Door Panel	35 <sup>3</sup> / <sub>4</sub> " (908)	49 <sup>15</sup> / <sub>16</sub> " (1268)	
<b>FREEZER</b>	<b>W</b>	<b>H</b>	
Drawer Panel	35 <sup>3</sup> / <sub>4</sub> " (908)	18 <sup>11</sup> / <sub>16</sub> " (475)	
<b>BI-36UG</b>	<b>W</b>	<b>H</b>	
Window Cut-Out	25 <sup>1</sup> / <sub>2</sub> " (648)	39 <sup>11</sup> / <sub>16</sub> " (1008)	
Cut-Out Location	<b>A</b>		
	5 <sup>3</sup> / <sub>16</sub> " (132)		

Model BI-36UFD			
<b>REFRIGERATOR (2 PANELS)</b>	<b>W</b>	<b>H</b>	
Door Panels	17 <sup>5</sup> / <sub>8</sub> " (448)	49 <sup>15</sup> / <sub>16</sub> " (1268)	
<b>FREEZER</b>	<b>W</b>	<b>H</b>	
Drawer Panel	35 <sup>3</sup> / <sub>4</sub> " (908)	18 <sup>11</sup> / <sub>16</sub> " (475)	

### Framed Panel Specifications

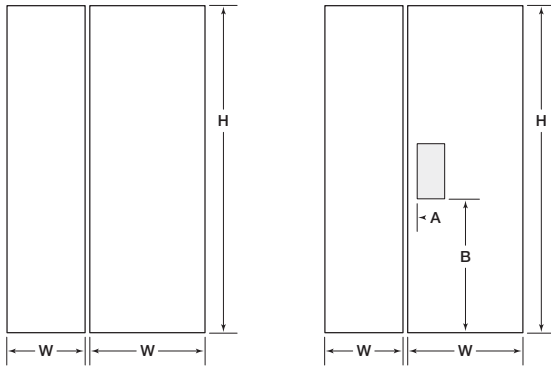

BI-36S / BI-42S / BI-42SID  
BI-48S / BI-48SID

BI-42SD / BI-48SD

Model BI-36S			
<b>REFRIGERATOR</b>	<b>W</b>	<b>H</b>	
Door Panel	19 <sup>13</sup> / <sub>16</sub> " (503)	69 <sup>9</sup> / <sub>16</sub> " (1767)	
<b>FREEZER</b>	<b>W</b>	<b>H</b>	
Door Panel	15 <sup>7</sup> / <sub>16</sub> " (392)	69 <sup>9</sup> / <sub>16</sub> " (1767)	

Models BI-42S, BI-42SID and BI-42SD			
<b>REFRIGERATOR</b>	<b>W</b>	<b>H</b>	
Door Panel	24 <sup>13</sup> / <sub>16</sub> " (630)	69 <sup>9</sup> / <sub>16</sub> " (1767)	
<b>FREEZER</b>	<b>W</b>	<b>H</b>	
Door Panel	16 <sup>7</sup> / <sub>16</sub> " (418)	69 <sup>9</sup> / <sub>16</sub> " (1767)	
<b>BI-42SD</b>	<b>W</b>	<b>H</b>	
Dispenser Cut-Out	5 <sup>7</sup> / <sub>8</sub> " (149)	12 <sup>7</sup> / <sub>16</sub> " (316)	
Cut-Out Location	<b>A</b>	<b>B</b>	
	1 <sup>7</sup> / <sub>8</sub> " (48)	28 <sup>3</sup> / <sub>4</sub> " (730)	

Models BI-48S, BI-48SID and BI-48SD			
<b>REFRIGERATOR</b>	<b>W</b>	<b>H</b>	
Door Panel	28 <sup>1</sup> / <sub>2</sub> " (724)	69 <sup>9</sup> / <sub>16</sub> " (1767)	
<b>FREEZER</b>	<b>W</b>	<b>H</b>	
Door Panel	18 <sup>3</sup> / <sub>4</sub> " (476)	69 <sup>9</sup> / <sub>16</sub> " (1767)	
<b>BI-48SD</b>	<b>W</b>	<b>H</b>	
Dispenser Cut-Out	5 <sup>7</sup> / <sub>8</sub> " (149)	12 <sup>7</sup> / <sub>16</sub> " (316)	
Cut-Out Location	<b>A</b>	<b>B</b>	
	1 <sup>7</sup> / <sub>8</sub> " (48)	28 <sup>3</sup> / <sub>4</sub> " (730)	

For models BI-42SD and BI-48SD, panel thickness in the dispenser area can range from 1/4" (6) to a maximum of 1 1/8" (29). If the panel is thicker, you must rout out a minimum 1/4" (6) flat landing area to accommodate the glasswell bezel.

### Overlay Panels

If your customer has chosen an overlay design application, make sure that the panels you are about to install match dimensions listed in the overlay panel specifications on pages 28–29. Additional panel design information can be found in the Sub-Zero design guide and on our website, subzero.com.

**IMPORTANT NOTE:** The size of the overlay panel is critical. It must fit over the door frame. Also, do not exceed the maximum per panel weight for your specific model. Refer to the chart below.

Overlay models are shipped without handle hardware. The cabinet manufacturer or designer will need to provide handle hardware to match the overall decorating scheme.

To install overlay panels, first remove the door trim molding. For side-by-side models and the upper door for over-and-under models, insert a screwdriver tip into the top corner slot on the handle side and pop out the trim molding. Remove the screws and frame. For the drawer on over-and-under models, insert a screwdriver tip into the slot on either side of the trim molding running along the top of the drawer and pop out the trim molding. Remove the screws and frame. Refer to the illustrations on page 23.

Sub-Zero allows a 1/4" (6) space to slide the backing material into place in the frame. If your material is thicker than a 1/4" (6), either rout an edge around the panel to get a proper fit or mount the decorative overlay panel on a sheet of 1/4" (6) thick material and insert the backing material into the channel.

Overlay Panel Requirements	
<b>MAX WEIGHT PER PANEL</b>	
BI-36R, BI-36RG and BI-36F	75 lbs (34 kg)
All Other Overlay Models	50 lbs (23 kg)
Grille Panel	13 lbs (6 kg)
<b>MIN PANEL THICKNESS</b>	
All Overlay Panels	5/8" (16)

You must allow for .10" (3) space between the backer board and the decorative panel, so the panel will slide easily into the door frame.

The illustrations below provide a cross section view of the three-panel assembly, showing placement of the trim and a rear view of the three-panel assembly with critical dimensions, standard for all built-in models.

Install the handle hardware before inserting the panel. We recommend larger D-style pulls. The use of small, one-piece knobs is not recommended. If you use screws with thick heads, you will need to countersink the screws into the backer panel before sliding the assembly into place.

Slide the panel into the frame on the door. With the panel in position, replace the frame end. Make sure the panel is inserted completely into the channel for proper fit and alignment.

To reinstall the trim molding on side-by-side models and the upper door for over-and-under models, insert the top of the trim molding into the grooves at the top of the door and work downward, snapping the trim molding into the clips on the frame.

For the drawer on over-and-under models, start at one end and move towards the opposite end, snapping the trim molding into the clips on the frame.

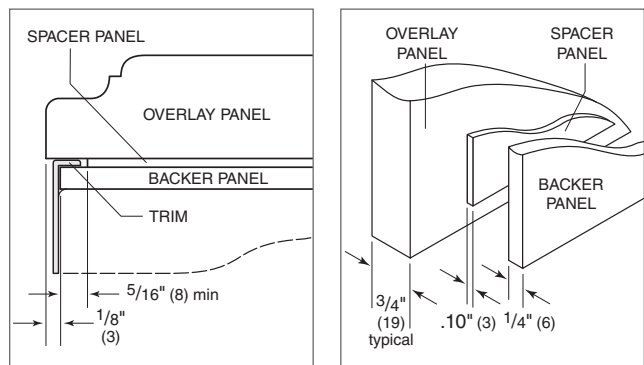

Panel assembly cross section.

Panel assembly rear view.

## Overlay Panels

### MODELS BI-42SD AND BI-48SD

The dispenser area of models BI-42SD and BI-48SD has been engineered to enable the use of the overlay or flush inset panel application. Installing overlay or flush inset panels for these models is the same procedure as for other built-in models. The refrigerator door panel will need to accommodate a cut-out for the glasswell bezel.

To remove the glasswell bezel for an overlay or flush inset model BI-42SD or BI-48SD, the water grille and touch pad must be removed. Lift the water grille up and out. Next, remove the touch pad assembly by removing the center plastic mandrel supports. Carefully tilt the touch pad out and disconnect the wire harness (blue side up) from the back side of the touch pad. Remove the bezel by removing the four screws.

Insert the overlay or flush inset panel into the door trim. Reverse the procedure to install the bezel, touch pad and water grille. To install the plastic rivets, insert rivets through the touch pad and into the control housing and secure by pressing mandrels into the body of the rivets. Refer to the illustrations below.

**IMPORTANT NOTE:** The total panel thickness (including backer and spacer, if used) in the glasswell bezel area can range from 1/4" (6) to a maximum of 1 1/8" (29). If the panel is thicker, provisions must be made to rout out a space to accommodate the bezel surrounding the glasswell.

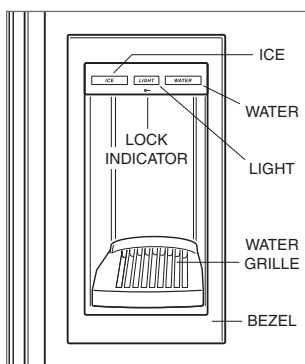

Dispenser glasswell bezel.

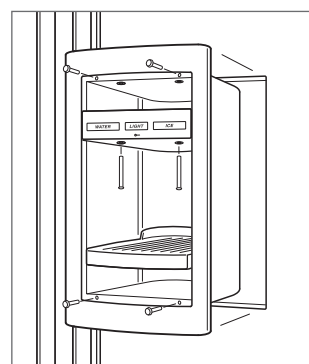

Glasswell bezel removal.

### GRILLE PANEL ASSEMBLY

Remove the grille panel assembly as described on page 16. Remove the top two corner screws and pull away the top frame. Slide the panel into position in the grille frame. If you are using a grille panel 1/4" (6) or thinner, you will need to install a filler.

Reattach the top frame by reinstalling the two top corner screws. Install the grille panel assembly onto the unit, by reversing the grille removal procedure outlined on page 16.

Refer to specifications for overlay grille panels on pages 28–29 and the illustrations on the previous page for the exact sizing of all three panels.

#### ▲ CAUTION

Do not exceed the panel dimensions listed for the appropriate overlay grille panel you are specifying. The overlay decorative panel cannot be any larger or it may restrict the air flow to the compressor area and cause problems with the operation of the Sub-Zero unit.



Overlay Panel Specifications

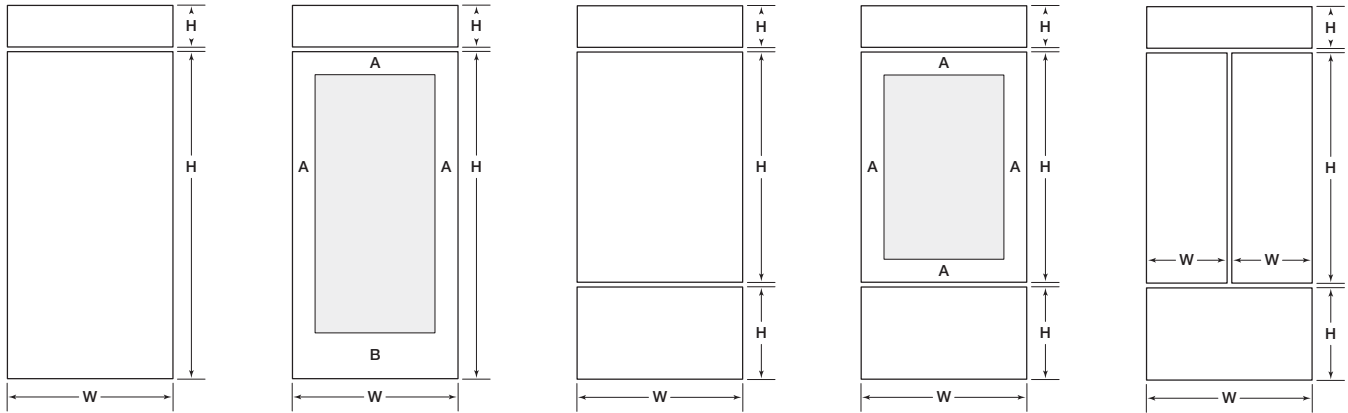

BI-36R / BI-36F

BI-36RG

BI-30U / BI-36U

BI-30UG / BI-36UG

BI-36UFD

Models BI-36R, BI-36RG and BI-36F			
<b>REFRIGERATOR / FREEZER</b>		<b>W</b>	<b>H</b>
Overlay Panel	36" (914)	69 <sup>3</sup> / <sub>4</sub> " (1772)	
Spacer Panel	35 <sup>1</sup> / <sub>8</sub> " (892)	68 <sup>15</sup> / <sub>16</sub> " (1751)	
Backer Panel	35 <sup>3</sup> / <sub>4</sub> " (908)	69 <sup>9</sup> / <sub>16</sub> " (1767)	
<b>GRILLE</b>		<b>W</b>	<b>H</b>
Overlay Panel	36" (914)	9 <sup>1</sup> / <sub>4</sub> " (235)*	
Spacer Panel	35 <sup>1</sup> / <sub>8</sub> " (892)	8 <sup>5</sup> / <sub>16</sub> " (211)	
Backer Panel	35 <sup>3</sup> / <sub>4</sub> " (908)	8 <sup>15</sup> / <sub>16</sub> " (227)	
<b>BI-36RG</b>		<b>W</b>	<b>H</b>
Window Cut-Out	25 <sup>1</sup> / <sub>2</sub> " (648)	54 <sup>1</sup> / <sub>8</sub> " (1375)	
	<b>A</b>	<b>B</b>	
Cut-Out Location	5 <sup>1</sup> / <sub>4</sub> " (133)	10 <sup>3</sup> / <sub>8</sub> " (264)	

Models BI-30U and BI-30UG			
<b>REFRIGERATOR</b>		<b>W</b>	<b>H</b>
Overlay Panel	30" (762)	50 <sup>1</sup> / <sub>8</sub> " (1273)	
Spacer Panel	29 <sup>1</sup> / <sub>8</sub> " (740)	49 <sup>5</sup> / <sub>16</sub> " (1253)	
Backer Panel	29 <sup>3</sup> / <sub>4</sub> " (756)	49 <sup>15</sup> / <sub>16</sub> " (1268)	
<b>FREEZER</b>		<b>W</b>	<b>H</b>
Overlay Panel	30" (762)	19" (483)	
Spacer Panel	29 <sup>1</sup> / <sub>8</sub> " (740)	18 <sup>1</sup> / <sub>16</sub> " (459)	
Backer Panel	29 <sup>3</sup> / <sub>4</sub> " (756)	18 <sup>11</sup> / <sub>16</sub> " (475)	
<b>GRILLE</b>		<b>W</b>	<b>H</b>
Overlay Panel	30" (762)	9 <sup>1</sup> / <sub>4</sub> " (235)*	
Spacer Panel	29 <sup>1</sup> / <sub>8</sub> " (740)	8 <sup>5</sup> / <sub>16</sub> " (211)	
Backer Panel	29 <sup>3</sup> / <sub>4</sub> " (756)	8 <sup>15</sup> / <sub>16</sub> " (227)	
<b>BI-30UG</b>		<b>W</b>	<b>H</b>
Window Cut-Out	19 <sup>1</sup> / <sub>2</sub> " (495)	39 <sup>5</sup> / <sub>8</sub> " (1006)	
		<b>A</b>	
Cut-Out Location		5 <sup>1</sup> / <sub>4</sub> " (133)	

Models BI-36U and BI-36UG			
<b>REFRIGERATOR</b>		<b>W</b>	<b>H</b>
Overlay Panel	36" (914)	50 <sup>1</sup> / <sub>8</sub> " (1273)	
Spacer Panel	35 <sup>1</sup> / <sub>8</sub> " (892)	49 <sup>5</sup> / <sub>16</sub> " (1253)	
Backer Panel	35 <sup>3</sup> / <sub>4</sub> " (908)	49 <sup>15</sup> / <sub>16</sub> " (1268)	
<b>FREEZER</b>		<b>W</b>	<b>H</b>
Overlay Panel	36" (914)	19" (483)	
Spacer Panel	35 <sup>1</sup> / <sub>8</sub> " (892)	18 <sup>1</sup> / <sub>16</sub> " (459)	
Backer Panel	35 <sup>3</sup> / <sub>4</sub> " (908)	18 <sup>11</sup> / <sub>16</sub> " (475)	
<b>GRILLE</b>		<b>W</b>	<b>H</b>
Overlay Panel	36" (914)	9 <sup>1</sup> / <sub>4</sub> " (235)*	
Spacer Panel	35 <sup>1</sup> / <sub>8</sub> " (892)	8 <sup>5</sup> / <sub>16</sub> " (211)	
Backer Panel	35 <sup>3</sup> / <sub>4</sub> " (908)	8 <sup>15</sup> / <sub>16</sub> " (227)	
<b>BI-36UG</b>		<b>W</b>	<b>H</b>
Window Cut-Out	25 <sup>1</sup> / <sub>2</sub> " (648)	39 <sup>5</sup> / <sub>8</sub> " (1006)	
		<b>A</b>	
Cut-Out Location		5 <sup>1</sup> / <sub>4</sub> " (133)	

Model BI-36UFD			
<b>REFRIGERATOR (2 PANELS)</b>		<b>W</b>	<b>H</b>
Overlay Panels	17 <sup>7</sup> / <sub>8</sub> " (454)	50 <sup>1</sup> / <sub>8</sub> " (1273)	
Spacer Panels	17" (432)	49 <sup>5</sup> / <sub>16</sub> " (1253)	
Backer Panels	17 <sup>5</sup> / <sub>8</sub> " (448)	49 <sup>15</sup> / <sub>16</sub> " (1268)	
<b>FREEZER</b>		<b>W</b>	<b>H</b>
Overlay Panel	36" (914)	19" (483)	
Spacer Panel	35 <sup>1</sup> / <sub>8</sub> " (892)	18 <sup>1</sup> / <sub>16</sub> " (459)	
Backer Panel	35 <sup>3</sup> / <sub>4</sub> " (908)	18 <sup>11</sup> / <sub>16</sub> " (475)	
<b>GRILLE</b>		<b>W</b>	<b>H</b>
Overlay Panel	36" (914)	9 <sup>1</sup> / <sub>4</sub> " (235)*	
Spacer Panel	35 <sup>1</sup> / <sub>8</sub> " (892)	8 <sup>5</sup> / <sub>16</sub> " (211)	
Backer Panel	35 <sup>3</sup> / <sub>4</sub> " (908)	8 <sup>15</sup> / <sub>16</sub> " (227)	

### Overlay Panel Specifications

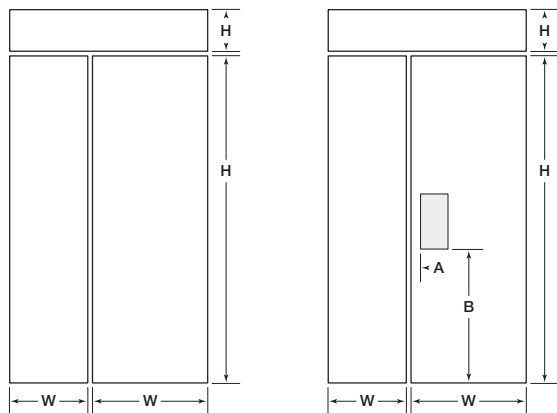

BI-36S / BI-42S / BI-42SID  
BI-48S / BI-48SID

BI-42SD / BI-48SD

Model BI-36S			
	W	H	
<b>REFRIGERATOR</b>			
Overlay Panel	20 <sup>1</sup> / <sub>16</sub> " (51)	69 <sup>3</sup> / <sub>4</sub> " (1772)	
Spacer Panel	19 <sup>3</sup> / <sub>16</sub> " (487)	68 <sup>15</sup> / <sub>16</sub> " (1751)	
Backer Panel	19 <sup>13</sup> / <sub>16</sub> " (503)	69 <sup>9</sup> / <sub>16</sub> " (1767)	
<b>FREEZER</b>			
Overlay Panel	15 <sup>11</sup> / <sub>16</sub> " (398)	69 <sup>3</sup> / <sub>4</sub> " (1772)	
Spacer Panel	14 <sup>13</sup> / <sub>16</sub> " (376)	68 <sup>15</sup> / <sub>16</sub> " (1751)	
Backer Panel	15 <sup>7</sup> / <sub>16</sub> " (392)	69 <sup>9</sup> / <sub>16</sub> " (1767)	
<b>GRILLE</b>			
Overlay Panel	36" (914)	9 <sup>1</sup> / <sub>4</sub> " (235)*	
Spacer Panel	35 <sup>1</sup> / <sub>8</sub> " (892)	8 <sup>5</sup> / <sub>16</sub> " (211)	
Backer Panel	35 <sup>3</sup> / <sub>4</sub> " (908)	8 <sup>15</sup> / <sub>16</sub> " (227)	

Models BI-42S, BI-42SID and BI-42SD			
	W	H	
<b>REFRIGERATOR</b>			
Overlay Panel	25 <sup>1</sup> / <sub>16</sub> " (637)	69 <sup>3</sup> / <sub>4</sub> " (1772)	
Spacer Panel	24 <sup>3</sup> / <sub>16</sub> " (614)	68 <sup>15</sup> / <sub>16</sub> " (1751)	
Backer Panel	24 <sup>13</sup> / <sub>16</sub> " (630)	69 <sup>9</sup> / <sub>16</sub> " (1767)	
<b>FREEZER</b>			
Overlay Panel	16 <sup>11</sup> / <sub>16</sub> " (424)	69 <sup>3</sup> / <sub>4</sub> " (1772)	
Spacer Panel	15 <sup>13</sup> / <sub>16</sub> " (402)	68 <sup>15</sup> / <sub>16</sub> " (1751)	
Backer Panel	16 <sup>7</sup> / <sub>16</sub> " (418)	69 <sup>9</sup> / <sub>16</sub> " (1767)	
<b>GRILLE</b>			
Overlay Panel	42" (1067)	9 <sup>1</sup> / <sub>4</sub> " (235)*	
Spacer Panel	41 <sup>1</sup> / <sub>8</sub> " (1045)	8 <sup>5</sup> / <sub>16</sub> " (211)	
Backer Panel	41 <sup>3</sup> / <sub>4</sub> " (1060)	8 <sup>15</sup> / <sub>16</sub> " (227)	
<b>BI-42SD</b>			
Dispenser Cut-Out	5 <sup>7</sup> / <sub>8</sub> " (149)	12 <sup>7</sup> / <sub>16</sub> " (316)	
	A	B	
Cut-Out Location	2" (51)	28 <sup>13</sup> / <sub>16</sub> " (732)	

Models BI-48S, BI-48SID and BI-48SD			
	W	H	
<b>REFRIGERATOR</b>			
Overlay Panel	28 <sup>3</sup> / <sub>4</sub> " (730)	69 <sup>3</sup> / <sub>4</sub> " (1772)	
Spacer Panel	27 <sup>7</sup> / <sub>8</sub> " (708)	68 <sup>15</sup> / <sub>16</sub> " (1751)	
Backer Panel	28 <sup>1</sup> / <sub>2</sub> " (724)	69 <sup>9</sup> / <sub>16</sub> " (1767)	
<b>FREEZER</b>			
Overlay Panel	19" (483)	69 <sup>3</sup> / <sub>4</sub> " (1772)	
Spacer Panel	18 <sup>1</sup> / <sub>8</sub> " (460)	68 <sup>15</sup> / <sub>16</sub> " (1751)	
Backer Panel	18 <sup>3</sup> / <sub>4</sub> " (476)	69 <sup>9</sup> / <sub>16</sub> " (1767)	
<b>GRILLE</b>			
Overlay Panel	48" (1219)	9 <sup>1</sup> / <sub>4</sub> " (235)*	
Spacer Panel	47 <sup>1</sup> / <sub>8</sub> " (1197)	8 <sup>5</sup> / <sub>16</sub> " (211)	
Backer Panel	47 <sup>3</sup> / <sub>4</sub> " (1213)	8 <sup>15</sup> / <sub>16</sub> " (227)	
<b>BI-48SD</b>			
Dispenser Cut-Out	5 <sup>7</sup> / <sub>8</sub> " (149)	12 <sup>7</sup> / <sub>16</sub> " (316)	
	A	B	
Cut-Out Location	2" (51)	28 <sup>13</sup> / <sub>16</sub> " (732)	

\*Height of overlay panel for grille may be increased by 1/2" (13) to hide upper main frame. For more information, refer to the built-in panel configurator at [subzero.com/trade/panels](http://subzero.com/trade/panels).

For all models, grille panel dimensions listed are for standard 84" (2134) nominal finished height. For 83" (2108) finished height, subtract 1" (25) from grille panel height dimensions. For 88" (2235) finished height, add 4" (102) to grille panel. An 83" (2108) or 88" (2235) panel grille must be ordered to accept an 83" (2108) or 88" (2235) custom panel. Width dimensions do not vary.

### Flush Inset Panels

If your customer has chosen the flush inset panel application, make sure that the panels you are about to install match dimensions listed in the flush inset panel specifications on pages 32–33. Additional panel design information can be found in the Sub-Zero design guide and on our website, subzero.com.

**IMPORTANT NOTE:** The size of the flush inset panel is critical. It must be sized correctly for a proper fit inside the opening.

Overlay models are shipped without handle hardware. The cabinet manufacturer or designer will provide handle hardware at the job site to match the overall decorating scheme.

To install flush inset panels, first remove the door trim molding. For side-by-side models and the upper door for over-and-under models, insert a screwdriver tip into the top corner slot on the handle side and pop out the trim molding. Remove the screws and frame. For the drawer on over-and-under models, insert a screwdriver tip into the slot on either side of the trim molding running along the top of the drawer, and pop out the trim molding. Remove the screws and frame. Refer to the illustrations on page 23.

Flush Inset Panel Requirements	
<b>MAX WEIGHT PER PANEL</b>	
BI-36R, BI-36RG and BI-36F	75 lbs (34 kg)
All Other Flush Inset Models	50 lbs (23 kg)
Grille Panel	13 lbs (6 kg)
<b>MIN PANEL THICKNESS</b>	
All Flush Inset Panels	5/8" (16)

Sub-Zero allows a 1/4" (6) space to slide the backing material into place in the frame. If your material is thicker than a 1/4" (6), either rout an edge around the panel to get a proper fit or mount the decorative flush inset panel on a sheet of 1/4" (6) thick material and insert the backing material into the channel.

You must allow for 0.10" (3) space between the backer board and the decorative panel, so the panel will slide easily into the door frame.

The illustration below provides a rear view of the three-panel assembly with critical dimensions, standard for all built-in models.

**IMPORTANT NOTE:** With the panels installed, 1/2" (13) minimum reveals must be kept on all sides to ensure proper door opening and sufficient cooling of the unit.

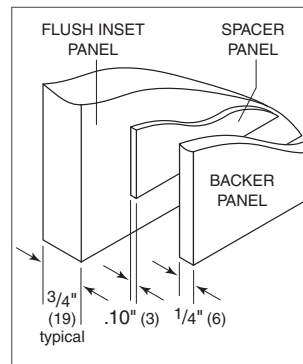

Three-panel assembly.

## Flush Inset Panels

Install the handle hardware before inserting the panel. Sub-Zero recommends using larger D-style pulls. The use of small, one-piece knobs is not recommended. If you use screws with thick heads, you will need to countersink the screws into the backer panel before sliding the assembly into place.

Slide the panel into the frame on the door. With the panel in position, replace the frame end. Make sure the panel is inserted completely into the channel for proper fit and alignment.

To reinstall the trim molding on side-by-side models and the upper door for over-and-under models, insert the top of the trim molding into the grooves at the top of the door and work downward, snapping the trim molding into the clips on the frame.

For the drawer on over-and-under models, start at one end and move towards the opposite end, snapping the trim molding into the clips on the frame.

## GRILLE PANEL ASSEMBLY

Remove the grille panel assembly as described on page 16. Remove the top two corner screws and pull away the top frame. Slide the panel into position in the grille frame. If you are using a grille panel  $\frac{1}{4}$ " (6) or thinner, you will need to install a filler.

Reattach the top frame by reinstalling the two top corner screws. Install the inner grille panel assembly onto the unit, by reversing the grille removal procedure outlined on page 16.

Refer to specifications for flush inset grille panels on pages 32–33 and the illustrations on the previous page for the exact sizing of all three panels.

### **▲ CAUTION**

**Do not exceed the panel dimensions listed for the appropriate flush inset grille panel you are specifying. The flush inset decorative panel cannot be any larger or it may restrict the air flow to the compressor area and cause problems with the operation of the Sub-Zero unit.**

### Flush Inset Panel Specifications

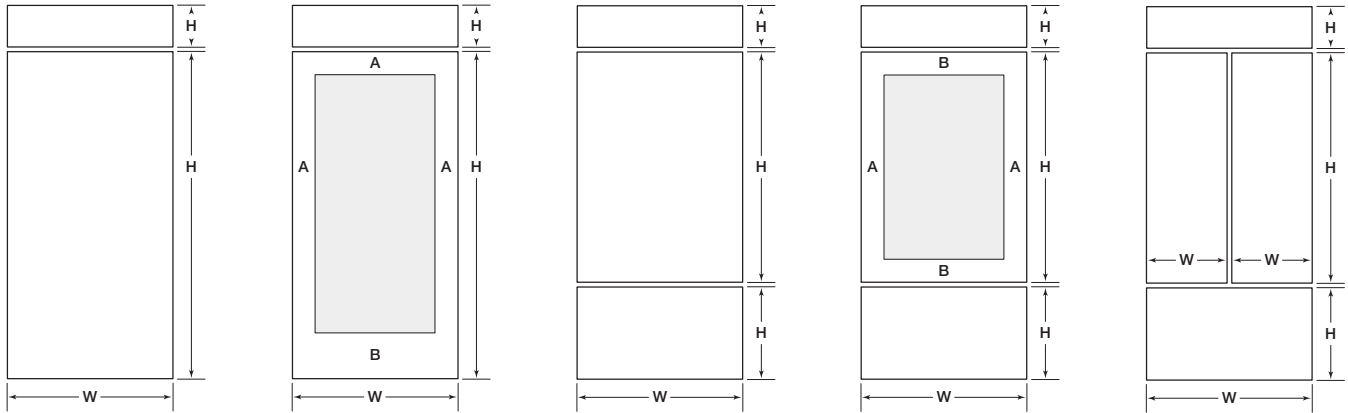

BI-36R / BI-36F

BI-36RG

BI-30U / BI-36U

BI-30UG / BI-36UG

BI-36UFD

Models BI-36R, BI-36RG and BI-36F			
<b>REFRIGERATOR / FREEZER</b>		<b>W</b>	<b>H</b>
Flush Inset Panel	37" (940)	69 <sup>3</sup> / <sub>4</sub> " (1772)	
Spacer Panel	35 <sup>1</sup> / <sub>8</sub> " (892)	68 <sup>15</sup> / <sub>16</sub> " (1751)	
Backer Panel	35 <sup>3</sup> / <sub>4</sub> " (908)	69 <sup>9</sup> / <sub>16</sub> " (1767)	
<b>GRILLE</b>		<b>W</b>	<b>H</b>
Flush Inset Panel	37" (940)	9 <sup>1</sup> / <sub>4</sub> " (235)	
Spacer Panel	35 <sup>1</sup> / <sub>8</sub> " (892)	8 <sup>5</sup> / <sub>16</sub> " (211)	
Backer Panel	35 <sup>3</sup> / <sub>4</sub> " (908)	8 <sup>15</sup> / <sub>16</sub> " (227)	
<b>BI-36RG</b>		<b>W</b>	<b>H</b>
Window Cut-Out	25 <sup>1</sup> / <sub>2</sub> " (648)	54 <sup>1</sup> / <sub>8</sub> " (1375)	
	<b>A</b>	<b>B</b>	
Cut-Out Location	5 <sup>3</sup> / <sub>4</sub> " (146)	10 <sup>3</sup> / <sub>8</sub> " (264)	

Models BI-30U and BI-30UG			
<b>REFRIGERATOR</b>		<b>W</b>	<b>H</b>
Flush Inset Panel	31" (787)	50 <sup>1</sup> / <sub>8</sub> " (1273)	
Spacer Panel	29 <sup>1</sup> / <sub>8</sub> " (740)	49 <sup>5</sup> / <sub>16</sub> " (1253)	
Backer Panel	29 <sup>3</sup> / <sub>4</sub> " (756)	49 <sup>15</sup> / <sub>16</sub> " (1268)	
<b>FREEZER</b>		<b>W</b>	<b>H</b>
Flush Inset Panel	31" (787)	19" (483)	
Spacer Panel	29 <sup>1</sup> / <sub>8</sub> " (740)	18 <sup>1</sup> / <sub>16</sub> " (459)	
Backer Panel	29 <sup>3</sup> / <sub>4</sub> " (756)	18 <sup>11</sup> / <sub>16</sub> " (475)	
<b>GRILLE</b>		<b>W</b>	<b>H</b>
Flush Inset Panel	31" (787)	9 <sup>1</sup> / <sub>4</sub> " (235)	
Spacer Panel	29 <sup>1</sup> / <sub>8</sub> " (740)	8 <sup>5</sup> / <sub>16</sub> " (211)	
Backer Panel	29 <sup>3</sup> / <sub>4</sub> " (756)	8 <sup>15</sup> / <sub>16</sub> " (227)	
<b>BI-30UG</b>		<b>W</b>	<b>H</b>
Window Cut-Out	19 <sup>1</sup> / <sub>2</sub> " (495)	39 <sup>5</sup> / <sub>8</sub> " (1006)	
	<b>A</b>	<b>B</b>	
Cut-Out Location	5 <sup>3</sup> / <sub>4</sub> " (146)	5 <sup>1</sup> / <sub>4</sub> " (133)	

Models BI-36U and BI-36UG			
<b>REFRIGERATOR</b>		<b>W</b>	<b>H</b>
Flush Inset Panel	37" (940)	50 <sup>1</sup> / <sub>8</sub> " (1273)	
Spacer Panel	35 <sup>1</sup> / <sub>8</sub> " (892)	49 <sup>5</sup> / <sub>16</sub> " (1253)	
Backer Panel	35 <sup>3</sup> / <sub>4</sub> " (908)	49 <sup>15</sup> / <sub>16</sub> " (1268)	
<b>FREEZER</b>		<b>W</b>	<b>H</b>
Flush Inset Panel	37" (940)	19" (483)	
Spacer Panel	35 <sup>1</sup> / <sub>8</sub> " (892)	18 <sup>1</sup> / <sub>16</sub> " (459)	
Backer Panel	35 <sup>3</sup> / <sub>4</sub> " (908)	18 <sup>11</sup> / <sub>16</sub> " (475)	
<b>GRILLE</b>		<b>W</b>	<b>H</b>
Flush Inset Panel	37" (940)	9 <sup>1</sup> / <sub>4</sub> " (235)	
Spacer Panel	35 <sup>1</sup> / <sub>8</sub> " (892)	8 <sup>5</sup> / <sub>16</sub> " (211)	
Backer Panel	35 <sup>3</sup> / <sub>4</sub> " (908)	8 <sup>15</sup> / <sub>16</sub> " (227)	
<b>BI-36UG</b>		<b>W</b>	<b>H</b>
Window Cut-Out	25 <sup>1</sup> / <sub>2</sub> " (648)	39 <sup>5</sup> / <sub>8</sub> " (1006)	
	<b>A</b>	<b>B</b>	
Cut-Out Location	5 <sup>3</sup> / <sub>4</sub> " (146)	5 <sup>1</sup> / <sub>4</sub> " (133)	

Model BI-36UFD			
<b>REFRIGERATOR (2 PANELS)</b>		<b>W</b>	<b>H</b>
Flush Inset Panels	18 <sup>3</sup> / <sub>8</sub> " (467)	50 <sup>1</sup> / <sub>8</sub> " (1273)	
Spacer Panels	17" (432)	49 <sup>5</sup> / <sub>16</sub> " (1253)	
Backer Panels	17 <sup>5</sup> / <sub>8</sub> " (448)	49 <sup>15</sup> / <sub>16</sub> " (1268)	
<b>FREEZER</b>		<b>W</b>	<b>H</b>
Flush Inset Panel	37" (940)	19" (483)	
Spacer Panel	35 <sup>1</sup> / <sub>8</sub> " (892)	18 <sup>1</sup> / <sub>16</sub> " (459)	
Backer Panel	35 <sup>3</sup> / <sub>4</sub> " (908)	18 <sup>11</sup> / <sub>16</sub> " (475)	
<b>GRILLE</b>		<b>W</b>	<b>H</b>
Flush Inset Panel	37" (940)	9 <sup>1</sup> / <sub>4</sub> " (235)	
Spacer Panel	35 <sup>1</sup> / <sub>8</sub> " (892)	8 <sup>5</sup> / <sub>16</sub> " (211)	
Backer Panel	35 <sup>3</sup> / <sub>4</sub> " (908)	8 <sup>15</sup> / <sub>16</sub> " (227)	

### Flush Inset Panel Specifications

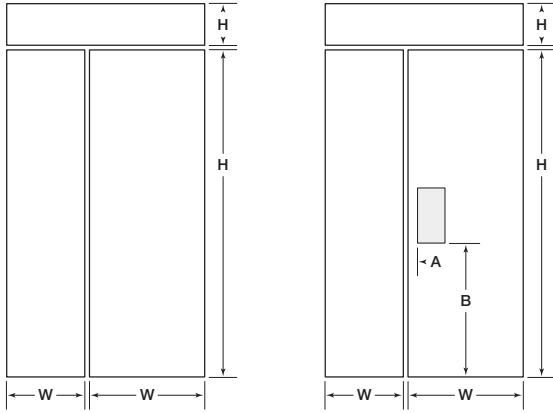

BI-36S / BI-42S / BI-42SID      BI-42SD / BI-48SD  
BI-48S / BI-48SID

Model BI-36S			
	W	H	
<b>REFRIGERATOR</b>			
Flush Inset Panel	20 <sup>9</sup> / <sub>16</sub> " (522)	69 <sup>3</sup> / <sub>4</sub> " (1772)	
Spacer Panel	19 <sup>3</sup> / <sub>16</sub> " (487)	68 <sup>15</sup> / <sub>16</sub> " (1751)	
Backer Panel	19 <sup>13</sup> / <sub>16</sub> " (503)	69 <sup>9</sup> / <sub>16</sub> " (1767)	
<b>FREEZER</b>			
Flush Inset Panel	16 <sup>3</sup> / <sub>16</sub> " (411)	69 <sup>3</sup> / <sub>4</sub> " (1772)	
Spacer Panel	14 <sup>13</sup> / <sub>16</sub> " (376)	68 <sup>15</sup> / <sub>16</sub> " (1751)	
Backer Panel	15 <sup>7</sup> / <sub>16</sub> " (392)	69 <sup>9</sup> / <sub>16</sub> " (1767)	
<b>GRILLE</b>			
Flush Inset Panel	37" (940)	9 <sup>1</sup> / <sub>4</sub> " (235)	
Spacer Panel	35 <sup>1</sup> / <sub>8</sub> " (892)	8 <sup>5</sup> / <sub>16</sub> " (211)	
Backer Panel	35 <sup>3</sup> / <sub>4</sub> " (908)	8 <sup>15</sup> / <sub>16</sub> " (227)	

Models BI-42S, BI-42SID and BI-42SD			
	W	H	
<b>REFRIGERATOR</b>			
Flush Inset Panel	25 <sup>9</sup> / <sub>16</sub> " (649)	69 <sup>3</sup> / <sub>4</sub> " (1772)	
Spacer Panel	24 <sup>3</sup> / <sub>16</sub> " (614)	68 <sup>15</sup> / <sub>16</sub> " (1751)	
Backer Panel	24 <sup>13</sup> / <sub>16</sub> " (630)	69 <sup>9</sup> / <sub>16</sub> " (1767)	
<b>FREEZER</b>			
Flush Inset Panel	17 <sup>3</sup> / <sub>16</sub> " (437)	69 <sup>3</sup> / <sub>4</sub> " (1772)	
Spacer Panel	15 <sup>13</sup> / <sub>16</sub> " (402)	68 <sup>15</sup> / <sub>16</sub> " (1751)	
Backer Panel	16 <sup>7</sup> / <sub>16</sub> " (418)	69 <sup>9</sup> / <sub>16</sub> " (1767)	
<b>GRILLE</b>			
Flush Inset Panel	43" (1092)	9 <sup>1</sup> / <sub>4</sub> " (235)	
Spacer Panel	41 <sup>1</sup> / <sub>8</sub> " (1045)	8 <sup>5</sup> / <sub>16</sub> " (211)	
Backer Panel	41 <sup>3</sup> / <sub>4</sub> " (1060)	8 <sup>15</sup> / <sub>16</sub> " (227)	
<b>BI-42SD</b>			
Dispenser Cut-Out	5 <sup>7</sup> / <sub>8</sub> " (149)	12 <sup>7</sup> / <sub>16</sub> " (316)	
	<b>A</b>	<b>B</b>	
Cut-Out Location	2" (51)	28 <sup>13</sup> / <sub>16</sub> " (732)	

Models BI-48S, BI-48SID and BI-48SD			
	W	H	
<b>REFRIGERATOR</b>			
Flush Inset Panel	29 <sup>1</sup> / <sub>4</sub> " (743)	69 <sup>3</sup> / <sub>4</sub> " (1772)	
Spacer Panel	27 <sup>7</sup> / <sub>8</sub> " (708)	68 <sup>15</sup> / <sub>16</sub> " (1751)	
Backer Panel	28 <sup>1</sup> / <sub>2</sub> " (724)	69 <sup>9</sup> / <sub>16</sub> " (1767)	
<b>FREEZER</b>			
Flush Inset Panel	19 <sup>1</sup> / <sub>2</sub> " (495)	69 <sup>3</sup> / <sub>4</sub> " (1772)	
Spacer Panel	18 <sup>1</sup> / <sub>8</sub> " (460)	68 <sup>15</sup> / <sub>16</sub> " (1751)	
Backer Panel	18 <sup>3</sup> / <sub>4</sub> " (476)	69 <sup>9</sup> / <sub>16</sub> " (1767)	
<b>GRILLE</b>			
Flush Inset Panel	49" (1245)	9 <sup>1</sup> / <sub>4</sub> " (235)	
Spacer Panel	47 <sup>1</sup> / <sub>8</sub> " (1197)	8 <sup>5</sup> / <sub>16</sub> " (211)	
Backer Panel	47 <sup>3</sup> / <sub>4</sub> " (1213)	8 <sup>15</sup> / <sub>16</sub> " (227)	
<b>BI-48SD</b>			
Dispenser Cut-Out	5 <sup>7</sup> / <sub>8</sub> " (149)	12 <sup>7</sup> / <sub>16</sub> " (316)	
	<b>A</b>	<b>B</b>	
Cut-Out Location	2" (51)	28 <sup>13</sup> / <sub>16</sub> " (732)	

For all models, grille panel dimensions listed are for standard 84" (2134) nominal finished height. For 83" (2108) finished height, subtract 1" (25) from grille panel height dimensions. For 88" (2235) finished height, add 4" (102) to grille panel. An 83" (2108) or 88" (2235) panel grille must be ordered to accept an 83" (2108) or 88" (2235) custom panel. Width dimensions do not vary.

### Flush Inset Panels

Illustrations A–F provide panel offsets and reveals for all built-in models in a flush inset application. Refer to the chart below for reference to the illustrations relating to your specific model.

For additional information on model specific panel reveals, visit the specification library section of our website, [subzerotrade.com](http://subzerotrade.com).

Panel Offsets	Illus.
<b>ALL REFRIGERATOR / ALL FREEZER</b>	
Door / Grille Sides	A
Grille Top	C
Grille Bottom / Door Top	D
Door Bottom	F
<b>OVER-AND-UNDER</b>	
Door (hinge) / Drawer / Grille Sides	A
Doors (handle) Sides (French door)	B
Grille Top	C
Grille Bottom / Door Top	D
Door Bottom / Drawer Top	E
Drawer Bottom	F
<b>SIDE-BY-SIDE</b>	
Doors (hinge) / Grille Sides	A
Doors (handle) Sides	B
Grille Top	C
Grille Bottom / Door Top	D
Door Bottom	F

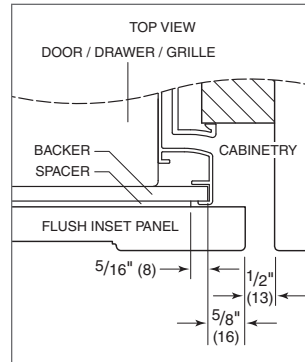

Illus. A

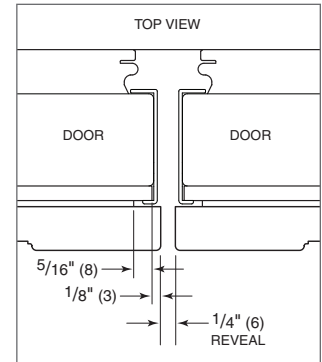

Illus. B

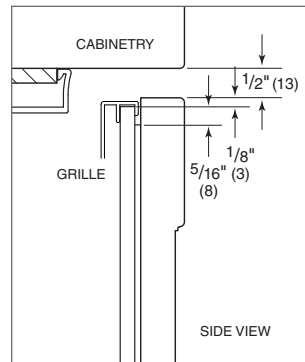

Illus. C

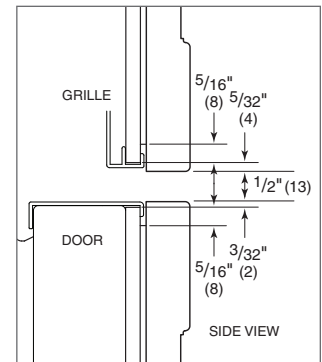

Illus. D

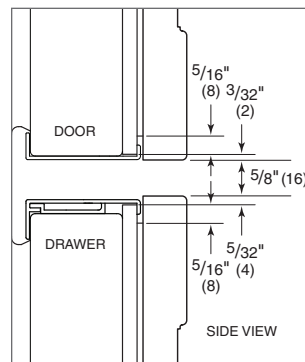

Illus. E

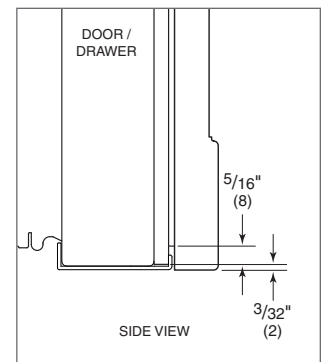

Illus. F

### Side Panels

**IMPORTANT NOTE:** Side panels will need to be installed before the unit is placed in its final position.

When installing a built-in unit with a custom side panel, an accessory kit is required. Stainless steel and white enamel side panels are available through your authorized Sub-Zero dealer. Refer to instructions included with the side panel kit when installing these side panels. For local dealer information, visit the find a showroom section of our website, subzero.com.

**IMPORTANT NOTE:** The use of side panels may change the width of your rough opening.

#### CUSTOM SIDE PANEL INSTALLATION

The custom side panel will need to be a minimum of 24" (610) deep and 1/2" (13) thick. Routing will be necessary for the side panel to fit flush against the side of the unit. Refer to the illustrations below.

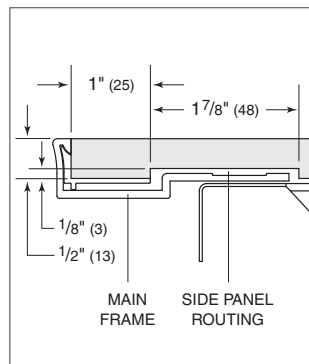
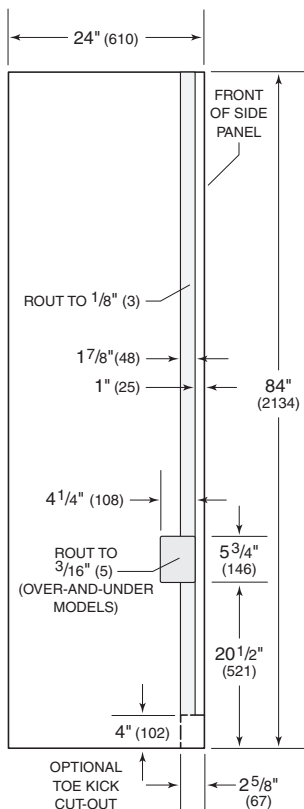

Routing detail.

**IMPORTANT NOTE:** The overall height on the side panel will vary with the height of the grille being used. Make sure you know your finished height before cutting any panels.

Install the brackets provided in the kit onto the side panel in the locations shown in the illustration below. The front brackets are meant to engage the mainframe and the back brackets will wrap behind the unit when the panel is in place. Screws are provided in the kit. If the provided screws will not work for your installation, you will need to provide the necessary screws to attach the brackets.

**IMPORTANT NOTE:** If you have a model BI-30U, BI-30UG, BI-36U, BI-36UG or BI-36UFD, extra routing will be necessary to avoid having the panel hit the refrigerator lower hinge plate.

Place the panel at a 75° angle and engage the front brackets into the mainframe. Swing the panel inward, making sure that the front brackets engage the mainframe. With the panel in position, attach the rear brackets to the rear of the unit with the screws provided. Check to see that the panel is secure. Refer to the illustration below.

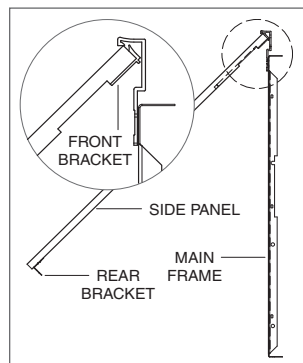

Side panel attachment (top view).

Side panel dimensions.



## Dual Installation

When two built-in units are installed side by side, a Sub-Zero built-in dual installation kit may be required. Contact your authorized Sub-Zero dealer for the proper components and installation instructions. For questions regarding the installation, call Sub-Zero at 800-222-7820. For local dealer information, visit the find a showroom section of our website, [subzero.com](http://subzero.com).

### DUAL STANDARD INSTALLATIONS

Two framed, overlay or stainless steel units may be placed side by side in a dual installation. Some dual standard installations will require a dual installation kit, available through your authorized Sub-Zero dealer.

A custom filler strip can be used in between two units in a framed, overlay or stainless steel design application. It is recommended that the filler strip be at least 2" (51) wide, to prevent condensation between the units. Be sure to add the filler strip width to your rough opening width.

Dual installations without a filler strip can only be accomplished using two units with opposite hinges as shown in illustration A below. The dual installations shown in illustrations B and C require a filler strip.

**IMPORTANT NOTE:** For the application shown in illustration A, a dual installation accessory kit is required.

### DUAL FLUSH INSET INSTALLATIONS

Installing two built-in models side by side in a flush inset application will require adjustments to the dimensions of your finished rough opening, panel sizes and panel offsets. It will also require a dual installation kit, available through your authorized Sub-Zero dealer.

Dual installations without a filler strip can only be accomplished using two units with opposite hinges as shown in illustration A below. The dual installations shown in illustrations B and C require a filler strip. Illustration A is the only application that will accommodate the dual wide grille.

**IMPORTANT NOTE:** The application shown in illustration A can only be achieved by installing dual flush inset panels. Failure to install dual flush inset panels will cause the handle side of the panels to collide when closing. In this application a dual installation accessory kit is also required.

Dual flush inset panels and dual installation kits are available through your authorized Sub-Zero dealer. Refer to the following page for dual flush inset panel specifications.

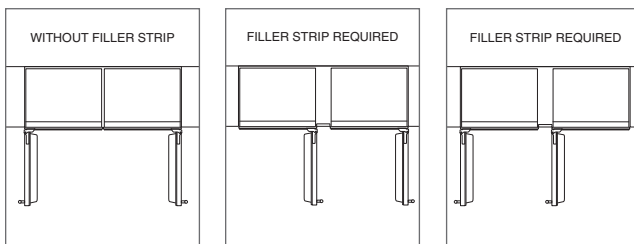

Illus. A

Illus. B

Illus. C

## Dual Installation—Flush Inset Panel Specifications

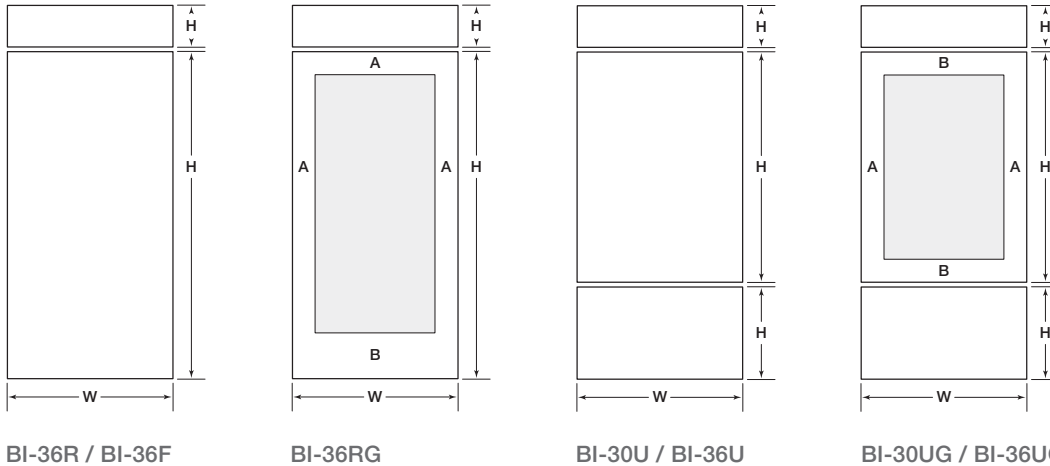

BI-36R / BI-36F

BI-36RG

BI-30U / BI-36U

BI-30UG / BI-36UG

Models BI-36R, BI-36RG and BI-36F			
<b>REFRIGERATOR / FREEZER</b>	<b>W</b>	<b>H</b>	
Flush Inset Panel	36 <sup>1</sup> / <sub>2</sub> " (927)	69 <sup>3</sup> / <sub>4</sub> " (1772)	
Spacer Panel	35 <sup>1</sup> / <sub>8</sub> " (892)	68 <sup>15</sup> / <sub>16</sub> " (1751)	
Backer Panel	35 <sup>3</sup> / <sub>4</sub> " (908)	69 <sup>9</sup> / <sub>16</sub> " (1767)	
<b>GRILLE</b>	<b>W</b>	<b>H</b>	
Flush Inset Panel	36 <sup>1</sup> / <sub>2</sub> " (927)	9 <sup>1</sup> / <sub>4</sub> " (235)	
Spacer Panel	35 <sup>1</sup> / <sub>8</sub> " (892)	8 <sup>5</sup> / <sub>16</sub> " (211)	
Backer Panel	35 <sup>3</sup> / <sub>4</sub> " (908)	8 <sup>15</sup> / <sub>16</sub> " (227)	
<b>BI-36RG</b>	<b>W</b>	<b>H</b>	
Window Cut-Out	25" (635)	54 <sup>1</sup> / <sub>8</sub> " (1375)	
	<b>A</b>	<b>B</b>	
Cut-Out Location	5 <sup>3</sup> / <sub>4</sub> " (146)	10 <sup>3</sup> / <sub>8</sub> " (264)	

Models BI-30U and BI-30UG			
<b>REFRIGERATOR</b>	<b>W</b>	<b>H</b>	
Flush Inset Panel	30 <sup>1</sup> / <sub>2</sub> " (775)	50 <sup>1</sup> / <sub>8</sub> " (1273)	
Spacer Panel	29 <sup>1</sup> / <sub>8</sub> " (740)	49 <sup>5</sup> / <sub>16</sub> " (1253)	
Backer Panel	29 <sup>3</sup> / <sub>4</sub> " (756)	49 <sup>15</sup> / <sub>16</sub> " (1268)	
<b>FREEZER</b>	<b>W</b>	<b>H</b>	
Flush Inset Panel	30 <sup>1</sup> / <sub>2</sub> " (775)	19" (483)	
Spacer Panel	29 <sup>1</sup> / <sub>8</sub> " (740)	18 <sup>1</sup> / <sub>16</sub> " (459)	
Backer Panel	29 <sup>3</sup> / <sub>4</sub> " (756)	18 <sup>11</sup> / <sub>16</sub> " (475)	
<b>GRILLE</b>	<b>W</b>	<b>H</b>	
Flush Inset Panel	30 <sup>1</sup> / <sub>2</sub> " (775)	9 <sup>1</sup> / <sub>4</sub> " (235)	
Spacer Panel	29 <sup>1</sup> / <sub>8</sub> " (740)	8 <sup>5</sup> / <sub>16</sub> " (211)	
Backer Panel	29 <sup>3</sup> / <sub>4</sub> " (756)	8 <sup>15</sup> / <sub>16</sub> " (227)	
<b>BI-30UG</b>	<b>W</b>	<b>H</b>	
Window Cut-Out	19" (483)	39 <sup>5</sup> / <sub>8</sub> " (1006)	
	<b>A</b>	<b>B</b>	
Cut-Out Location	5 <sup>3</sup> / <sub>4</sub> " (146)	5 <sup>1</sup> / <sub>4</sub> " (133)	

Models BI-36U and BI-36UG			
<b>REFRIGERATOR</b>	<b>W</b>	<b>H</b>	
Flush Inset Panel	36 <sup>1</sup> / <sub>2</sub> " (927)	50 <sup>1</sup> / <sub>8</sub> " (1273)	
Spacer Panel	35 <sup>1</sup> / <sub>8</sub> " (892)	49 <sup>5</sup> / <sub>16</sub> " (1253)	
Backer Panel	35 <sup>3</sup> / <sub>4</sub> " (908)	49 <sup>15</sup> / <sub>16</sub> " (1268)	
<b>FREEZER</b>	<b>W</b>	<b>H</b>	
Flush Inset Panel	36 <sup>1</sup> / <sub>2</sub> " (927)	19" (483)	
Spacer Panel	35 <sup>1</sup> / <sub>8</sub> " (892)	18 <sup>1</sup> / <sub>16</sub> " (459)	
Backer Panel	35 <sup>3</sup> / <sub>4</sub> " (908)	18 <sup>11</sup> / <sub>16</sub> " (475)	
<b>GRILLE</b>	<b>W</b>	<b>H</b>	
Flush Inset Panel	36 <sup>1</sup> / <sub>2</sub> " (927)	9 <sup>1</sup> / <sub>4</sub> " (235)	
Spacer Panel	35 <sup>1</sup> / <sub>8</sub> " (892)	8 <sup>5</sup> / <sub>16</sub> " (211)	
Backer Panel	35 <sup>3</sup> / <sub>4</sub> " (908)	8 <sup>15</sup> / <sub>16</sub> " (227)	
<b>BI-36UG</b>	<b>W</b>	<b>H</b>	
Window Cut-Out	25" (635)	39 <sup>5</sup> / <sub>8</sub> " (1006)	
	<b>A</b>	<b>B</b>	
Cut-Out Location	5 <sup>3</sup> / <sub>4</sub> " (146)	5 <sup>1</sup> / <sub>4</sub> " (133)	

Grille panel dimensions listed are for standard 84" (2134) nominal finished height. For 83" (2108) finished height, subtract 1" (25) from grille panel height dimensions. For 88" (2235) finished height, add 4" (102) to grille panel. Width dimensions do not vary.

### Dual Installation—Flush Inset Panels

When installing two built-in models side by side in a flush inset application, you must decrease the width of the decorative flush inset panels by 1/2" (13). Adjustments to the panel offsets will also need to be made. These adjustments are needed to achieve a proper fit and to ensure the panels do not collide when closing. Panel dimensions in the chart below have been adjusted to reflect the decrease in panel dimensions.

**IMPORTANT NOTE:** If a filler strip is not used, dual installations can only be accomplished using two units with opposite hinges.

Illustrations A–F provide panel offsets and reveals for all built-in models in a flush inset application. Refer to the chart below for reference to the illustrations relating to your specific model. All reveals are 1/2" (13) unless otherwise specified.

For additional information on model specific panel reveals, visit the specification library section of our website, [subzerotrade.com](http://subzerotrade.com).

Panel Offsets	Illus.
<b>ALL REFRIGERATOR / ALL FREEZER</b>	
Doors (hinge) / Grille Sides	A
Doors (handle) Sides	B
Grille Top	C
Grille Bottom / Door Top	D
Door Bottom	F
<b>OVER-AND-UNDER</b>	
Doors (hinge) / Drawer / Grille Sides	A
Doors (handle) Sides	B
Grille Top	C
Grille Bottom / Door Top	D
Door Bottom / Drawer Top	E
Drawer Bottom	F

**CAUTION**  
Do not exceed the flush inset decorative panel dimensions. Exceeding dimensions could cause damage to the panels and the Sub-Zero unit.

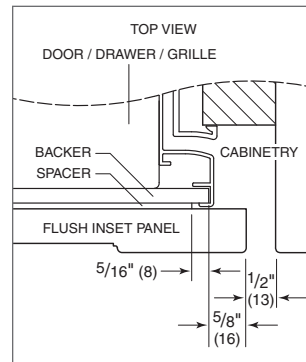

Illus. A

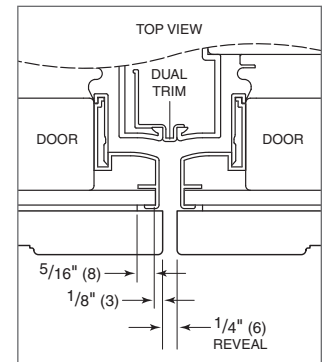

Illus. B

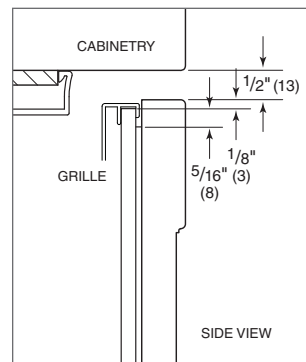

Illus. C

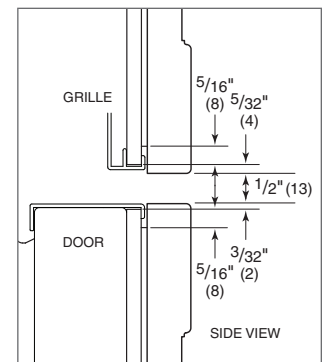

Illus. D

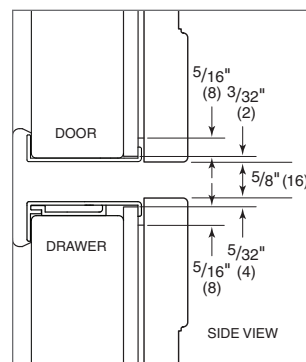

Illus. E

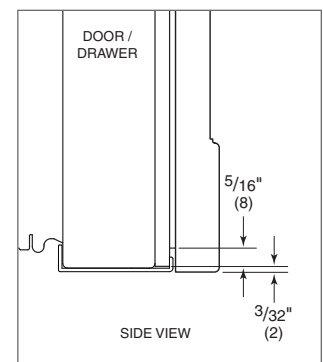

Illus. F