

1224KEGRSOD • 24" Outdoor Keg Refrigerator • Outdoor Series

FEATURES & BENEFITS



STAINLESS SOLID
(SINGLE TAP)



STAINLESS SOLID
(DOUBLE TAP)

PERFORMANCE	<ul style="list-style-type: none"> • Volume of 5.6 cu ft can fit up to one 1/4 slim barrel and one 1/6 barrel, or standard 1/4 barrel • Holds up to 111 bottles (12 oz) or 165 cans (12 oz) • Digital Touch Pad Control is conveniently located on upper face of unit • Temperature range: 34°F - 45°F • Convection cooling system rapidly and efficiently takes items to the set temperature
INTERIOR/EXTERIOR	<ul style="list-style-type: none"> • White interior is illuminated with LED lighting • Two chrome plated durable wire shelves • Removable stainless steel liner protects the interior floor • Standard professional stainless steel handle is interchangeable with commercial handle accessory • Full stainless steel cabinet and door are deemed suitable for outdoor use by UL • Door swing is field reversible, and is shipped right-hand hinged • Center top plug is removed when using Tap Tower Kits • Single Tap Tower Kit and Double Tap Tower Kit accessories sold separately • Tap Tower Kits include low profile tap head(s), CO2 tank and regulator, tubing and clamps, mounting hardware, black tap handle(s), drip tray, and cleaning kit
INTEGRATION	<ul style="list-style-type: none"> • Unit is designed to be built-in or can be freestanding with the freestanding accessory kit • Four independently adjustable leveling legs provide a precise undercounter fit • May be used for indoor applications

MODEL DETAILS

Model	Voltage/Hz	Door Swing	Finish	Shipping Weight
U-1224KEGRSOD-00A	115 / 60	Field Reversible	Stainless Solid	117 lbs

ACCESSORIES

Model	Description	Finish	Shipping Weight
80-54214-00	Commercial Door Handle, 7/8" Diameter	Stainless	2 lbs
U-FSK-S	Freestanding Kit	Stainless	3 lbs
U-SINGLETAP	Single Tap Tower Kit	Stainless	20 lbs
U-DOUBLETAP	Double Tap Tower Kit	Stainless	24 lbs

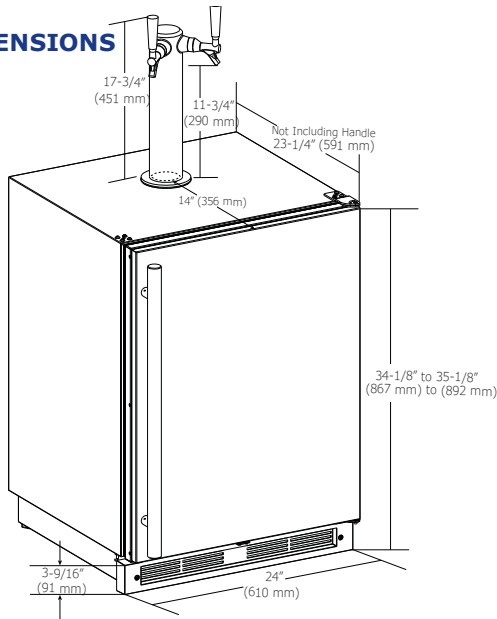
Outdoor Series • Outdoor Keg Refrigerator • 1224KEGRSOD
DIMENSIONS

SPECIFICATIONS

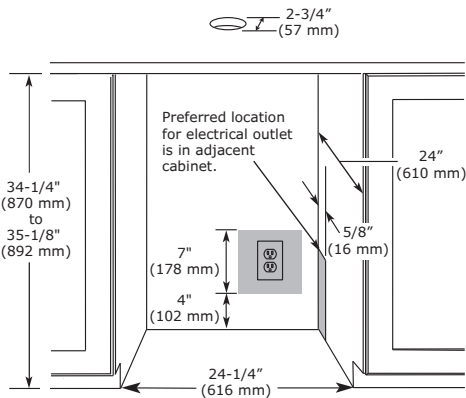
Model	1224KEGRSOD
Amps: Running	1.2
Capacity: Bottle (12 oz)	111
Capacity: Can (12 oz)	165
Capacity: Volume (cu ft)	5.6
Control Type	Digital Touch Pad
Dimensions: Product Depth	23 1/4" / 591 mm
Dimensions: Product Height	34 1/8" / 867 mm
Dimensions: Product Width	24" / 610 mm
Energy Consumption: Avg. Per Year	240 kWh
ENERGY STAR	ENERGY STAR / Tier 3
Product Weight: Max	107 lbs
Refrigerant Type	R600a
Sabbath (Star K Certified)	Yes
Temperature Range	34°F - 45°F

CABINET CUT-OUT

INSTALLATION NOTES

When installing adjacent to wall, ensure 2 1/2" clearance on hinged side for 90° door opening, allowing ample room for door handle.

Cutout includes the additional 1/4" width overall to ensure proper installation.

No additional clearance around sides, top or rear of unit is needed for ventilation.

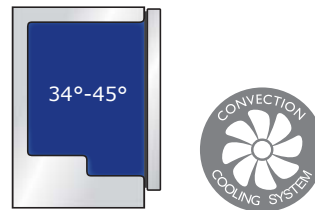
Do not obstruct front grille air flow.

COOLING SYSTEM

ELECTRICAL REQUIREMENTS

This unit requires a grounded, polarized 115 VAC, 60 Hz, 15 A power supply (normal household current).



Warranty

Please visit u-line.com to view this model's User Guide & Service Manual. All Specifications are subject to change without notice.

Deemed suitable for outdoor use by UL.