

24" Recessed Handle Dishwasher

800 Plus Series- Stainless steel

SHE9PT55UC



Features and Benefits

Key Features

- 39 dBA- Quietest Brand
- Flexible 3rd Rack with Adjustable Separators Provides Additional Loading Capacity
- Made in Germany
- TFT - Full-Color Clear Text Display
- SteelTouch™ Control Panel

Design

- Flexible 3rd Rack with Adjustable Separators Provides Additional Loading Capacity
- 15 Place Setting Capacity
- TFT - Full-Color Clear Text Display
- SteelTouch™ Control Panel
- RackMatic® on Upper Rack - 3 Height Adjustments and Up to 9 Possible Rack Positions
- Alternating Tines Fold Down to Accommodate Larger Cookware
- Extra Tall Item Sprinkler Cleans Items 22" Tall

Performance

- 39 dBA- Quietest Brand
- 6 Programs and 5 Options
- Detergent Tray Optimizes Detergent Dissolving
- Load Size Sensor Automates Wash Temperature
- Water Softener Ensures Perfect Shine
- Sanitize Option Eliminates Bacteria and Enhances Drying Results

Efficiency

Convenience



Notes: All height, width and depth dimensions are shown in inches. *Please refer to installation instructions prior to making cutout. BSH reserves the absolute and unrestricted right to change product materials and specifications, at any time, without notice. Consult the product's installation instructions for final dimensional data and other details. Applicable product warranty can be found in a accompanying product literature or you may contact your account manager for further details.

For more information on our entire line of products, go to boschappliances.com or call 1-800-944-2904.
Copyright ©2013 BSH Home Appliances Corporation. All rights reserved. Bosch is a registered trademark of Robert Bosch GmbH.

Litho Date: 10/2013



24" Recessed Handle Dishwasher

800 Plus Series- Stainless steel

SHE9PT55UC

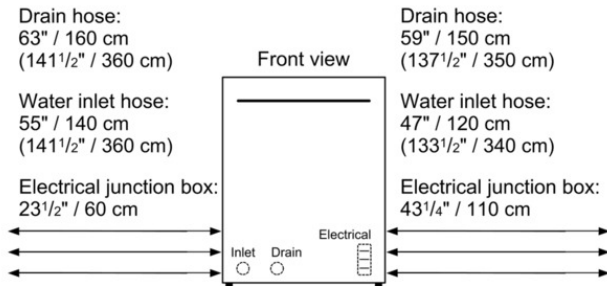

All connections in the rear of the appliance.
() values with extension kit.

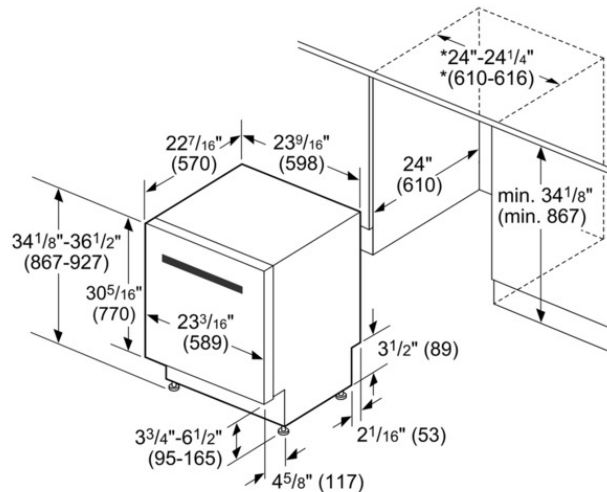

*23 5/8" (600) without decor strips

measurements in inches (mm)

Features

Watts (W)	1300
Current (A)	12
Volts (V)	120
Frequency (Hz)	60
Power Cord Length	63"
Minimum Water Pressure (lb/sin)	7.0
Length inlet hose (in)	55"
Length outlet hose (in)	63"
Overall appliance dimensions (HxWxD) (in)	34 1/8 " x 23 9/16 " x 22 7/16 "
Required cutout size (HxWxD) (in)	34 1/8 " x 24 " x 24 "
Adjustable feet	Yes

Technical Specification

Number of wash cycles	5
Number of options	6
Third Rack	
Tube material	Stainless steel
Concealed heating element	Yes
Leak protection system	24/7 Aqua Stop Plus
Five-level wash	Yes
Water softener	Yes
ChildLock	No
Total annual energy consumption (kWh)	239
Energy Efficiency Class	Tier 1
Energy Star® qualified	Yes
Total annual energy consumption (kWh)	623.5
Total annual water consumption (g)	624
Number of place settings	15

Notes: All height, width and depth dimensions are shown in inches. *Please refer to installation instructions prior to making cutout. BSH reserves the absolute and unrestricted right to change product materials and specifications, at any time, without notice. Consult the product's installation instructions for final dimensional data and other details. Applicable product warranty can be found in a accompanying product literature or you may contact your account manager for further details.

For more information on our entire line of products, go to boschappliances.com or call 1-800-944-2904.

Copyright ©2013 BSH Home Appliances Corporation. All rights reserved. Bosch is a registered trademark of Robert Bosch GmbH.

Litho Date: 10/2013

